

LINEAR MINIATURE GUIDE



ROLLCO

SPECIALIZED
ON LINEAR MOTION

Every care has been taken to ensure the accuracy of the information contained in this catalogue, but no liability can be accepted for any errors or omissions. We reserve the right to make changes without prior notice.

Any reproduction, even partial, is allowed only by written permission by Rollco.



**CLIMATE
COMPENSATED
PAPER**



Index

PRODUCT OVERVIEW	4
Characteristics	4
Features	6
DIMENSIONS	8
MR-M ZUE Series	9
MR-W ZUE Series	11
MR-M SS Series	13
MR-W SS Series	15
Standard MRU-M Series	16
Wide MRU-W Series	16
ORDER CODE	17
Linear Miniature Guides	17
Lubrication Injector	18
TECHNICAL INFORMATION	19
Length of Rail	19
Standard Type	19
Wide Type	19
Precision	20
Speed	20
Preload	20
Operating Temperature	21
Lubrication	21
Function	21
Lubrication Caution	21
Grease Lubrication	21
Oil Lubrication	21
Re-lubrication	22
Re-lubrication Interval	22
Lubrication Grease	22
Lubrication Oil	22
Friction	23
Sealing Design	23
Friction Factors	23
Load Capacity and Rating Life	23
Static Load Rating C_0	23
Static Load P_0 and Moment M_0	24
Static Load Safety Factor S_0	24
Dynamic Load Rating C_{100B}	24
Rating Life L	24
Calculation of Rating Life	24
Equivalent Dynamic Load and Speed	25
Equivalent Dynamic Load	25
Equivalent Speed	25
Combined Equivalent Dynamic Load	25
Under the Condition with the Moment	25
Single Block Bearing the Moment	25
Line Chart	26
Customization Requirements	28
INSTALLATION INSTRUCTIONS	29
Height and Chamfer of Reference Edge	29
Geometric and Positional Accuracy of the Mounting Surface	30
Reference Edge	30

Product Overview

This linear guide system in miniature sizes is suitable for applications with limited space. Typical application areas are pharmaceutical and electronic industries.

The rails are available in a wide and a narrow version with sizes ranging from 3 mm to 15 mm. The sliders come in narrow and wide version. The system has a very high load capacity in relation to its size.

Characteristics

- **Designed for high load, high moment applications**
- **Embedded inverse hook design**
- **Unique ball re-circulation design**
- **Our steel reinforcement plate ensures sturdy assembly and a longer product lifespan**
- **Precision**
MR Miniature linear guide series have three accuracy grades for design selections: Precision (P), High (H), Normal (N).
- **Lubrication storage**
Environmentally-friendly system requires less lubricant.
- **Material**
All of our MR miniature linear guide series are made from heat treated stainless steel material.
- **Built-in bottom seal**
We recommend this new design as a priority purchase.



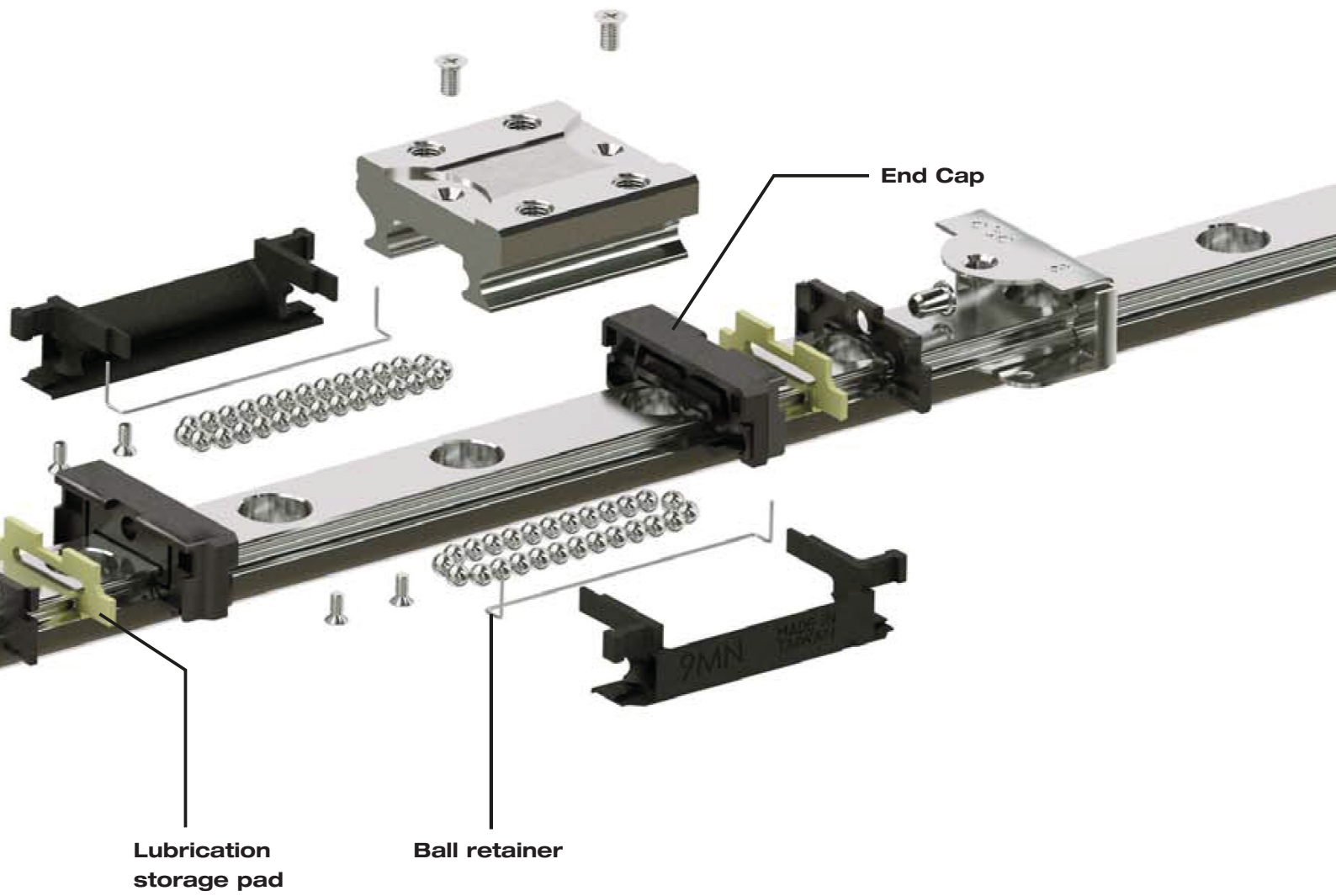

Features

Dust proof design

The standard end seal design can be hermetically sealed and dustproofed. This extends the product lifespan, reduces lubrication grease consumption, and ensures a long-lasting lubrication effect. The special seal slip design also ensures a low friction force so as not to affect the product's running smoothness.

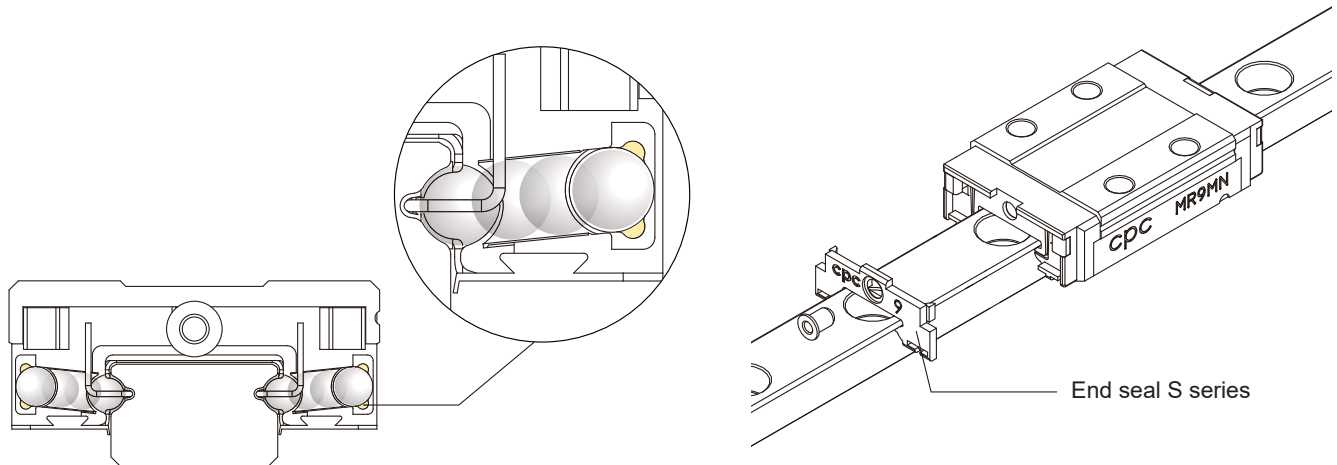

Sealing and reinforcement

ZUE series - end seal, bottom seal, reinforcing plate and lubrication pad

The newly designed bottom seal protects lubrication grease from spilling below the runner block. With our built-in lubrication pad, an additional grease saving effect is attained, further prolonging our product's re-lubrication timeframe. The new design is recommended for priority purchase.

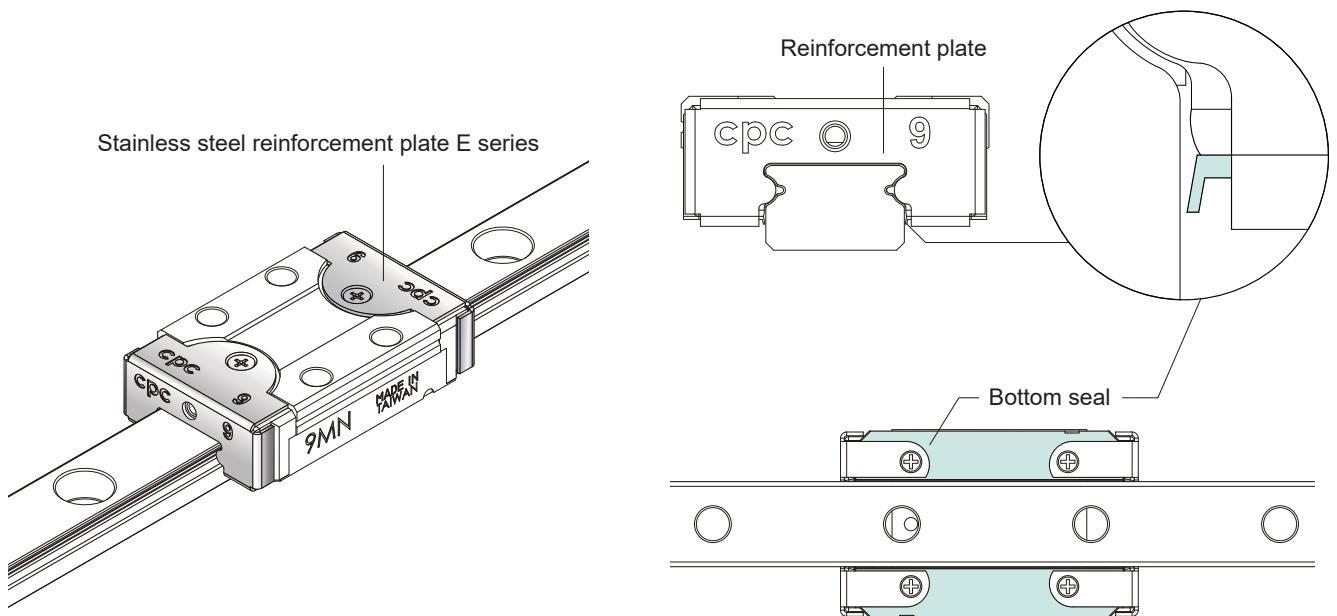

Embedded inverse hook design for reinforced mechanical integration

When the runner block is in motion and changing direction, the circulating stainless steel balls inside the raceway generate impact force against the plastic end cap. As the demand for rapid motion in the automation industry has increased, these blocks have inverse plastic hooks to tightly secure our miniature blocks by effectively distributing the applied stress over a larger area.

The new design is suitable for:

- High speed belt driven mechanisms
- High speed carrier designs
- Automation linkage between stations

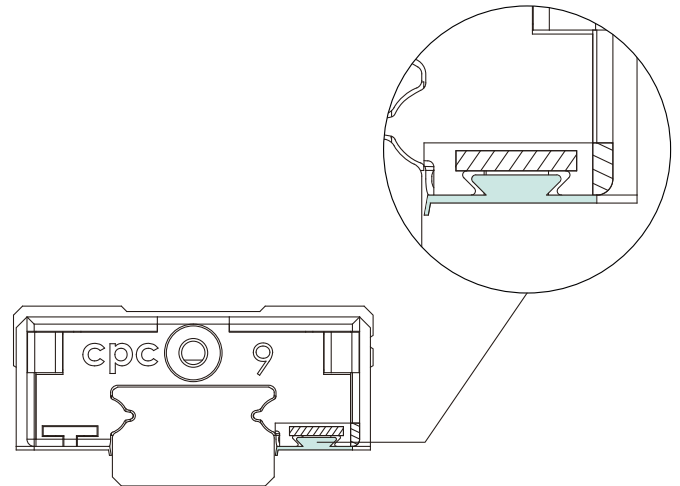

High load and high moment capacity

The MR Miniature Linear Guide Series is designed using two rows of recirculating balls. The design uses a Gothic profile with a 45° contact angle to achieve an equal load capacity in all directions. Within the restriction of limited space, larger stainless steel balls are used to enhance load and torsion resistance capacity.

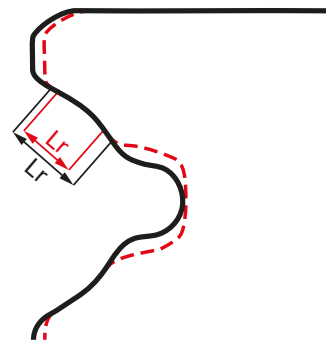
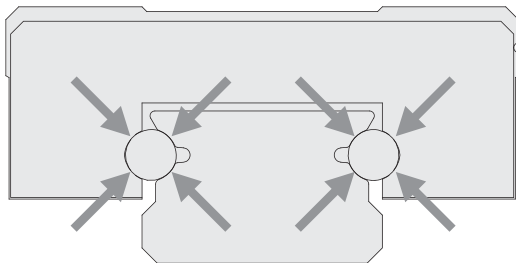

Under equal widthed rails, the black line indicates that our linear guides provide greater surface contact compared to competing products (indicated with the red-dotted line).

MR-M ZUE Series

Standard Narrow Rail Type

(End seal, bottom seal, reinforcement plate, lubrication storage)

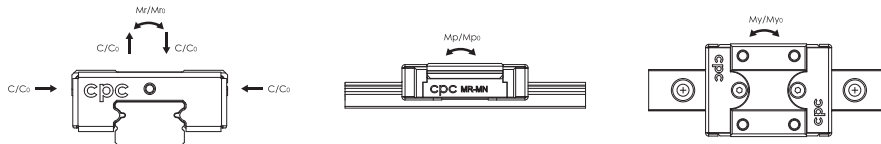
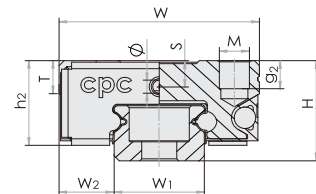
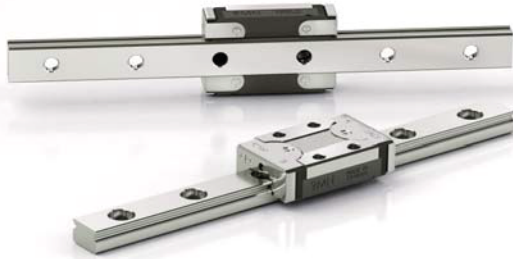

Size	Fabr. Dim.		Rail Dimension (mm)				Block Dimension (mm)					
	H	W ₂	W ₁	H ₁	P	D x d x g ₁	W	L	L ₁	h ₂	P ₁	P ₂
MR 5MN ZUE	6	3.5	5	3.5	15	3.5x2.4x1	12	16.6	10	5.0	-	8
MR 5ML ZUE	6	3.5	5	3.5	15	3.5x2.4x1	12	20.2	13.5	5.0	7	-
MR 9MN ZUE	10	5.5	9	5.5	20	6x3.5x3.5	20	31.6	20.5	8.5	10	15
MR 9ML ZUE	10	5.5	9	5.5	20	6x3.5x3.5	20	41.9	30.8	8.5	16	15
MR 12MN ZUE	13	7.5	12	7.5	25	6x3.5x4.5	27	36.8	22	10.9	15	20
MR 12ML ZUE	13	7.5	12	7.5	25	6x3.5x4.5	27	49	34	10.9	20	20
MR 15MN ZUE	16	8.5	15	9.5	40	6x3.5x4.5	32	44.6	27	13.1	20	25
MR 15ML ZUE	16	8.5	15	9.5	40	6x3.5x4.5	32	61.6	44	13.1	25	25

Load capacities are calculated according to ISO 14728. To compare the rating life definition and the load capacities:
 $C_{50B} = 1.26 \times C_{100B}$

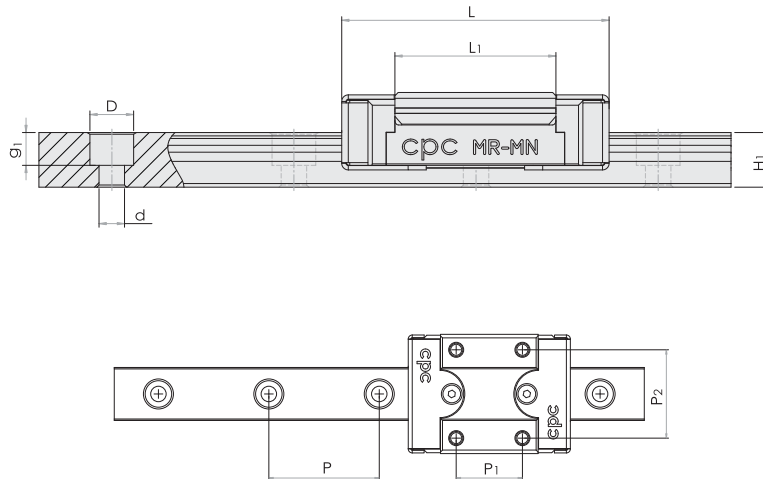

Block Dimension (mm)				Load Capacities (N)		Static Moment (Nm)			Weight		Size
M x g ₂	ø	S	T	C _{100B} (dyn)	C ₀ (stat)	M _{ro}	M _{po}	M _{yo}	Block (g)	Rail (g/m)	
M2x1.5	0.7	1.3	2	335	550	1.7	1	1	3.5	116	MR 5MN SUE
M2.6x2.0	0.7	1.3	2	470	900	2.4	2.1	2.1	4	116	MR 5ML SUE
M3x3.0	1.3	2.2	3.3	1570	2495	11.7	6.4	6.4	18	301	MR 9MN SUE
M3x3.0	1.3	2.2	3.3	2135	3880	18.2	12.4	12.4	28	301	MR 9ML SUE
M3x3.5	1.3	3.2	4.3	2308	3465	21.5	12.9	12.9	34	602	MR 12MN SUE
M3x3.5	1.3	3.2	4.3	3240	5630	34.9	30.2	30.2	51	602	MR 12ML SUE
M3x5.5	1.8	3.3	4.3	3810	5590	43.6	27	27	61	930	MR 15MN SUE
M3x5.5	1.8	3.3	4.3	5350	9080	70	63.3	63.3	90	930	MR 15ML SUE

MR-W ZUE Series

Wide Rail Type

(End seal, bottom seal, reinforcement plate, lubrication storage)

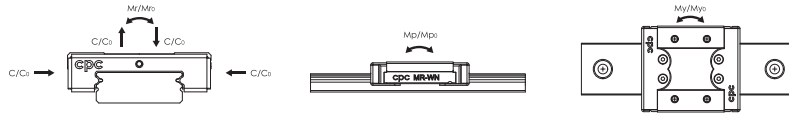
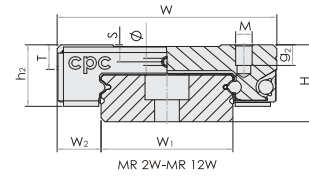
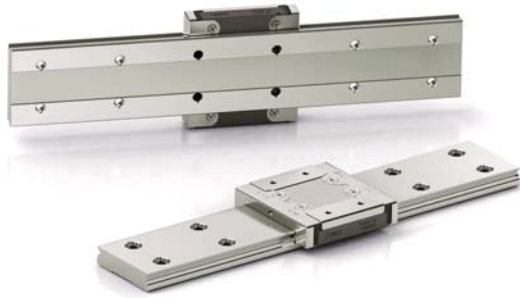

Size	Fabr. Dim.		Rail Dimension (mm)					Block Dimension (mm)					
	H	W ₂	W ₁	H ₁	P	P ₃	D x d x g ₁	W	L	L ₁	h ₂	P ₁	P ₂
MR 2WL ZUE	4	3	4	3	10	-	2.8x1.8x1.0	10	17.5	11.9	3.4	6.5	-
MR 7WN ZUE	9	5.5	14	5.2	30	-	6x3.5x3.5	25	32.5	21.2	7.6	10	19
MR 7WL ZUE	9	5.5	14	5.2	30	-	6x3.5x3.5	25	41.5	30.1	7.6	19	19
MR 9WN ZUE	12	6	18	7.3	30	-	6x3.5x4.5	30	40.2	27.9	9.4	12	21
MR 9WL ZUE	12	6	18	7.3	30	-	6x3.5x4.5	30	51.8	39.5	9.4	24	23
MR 12WN ZUE	14	8	24	8.5	40	-	8x4.5x4.5	40	45.8	31	11.2	15	28
MR 12WL ZUE	14	8	24	8.5	40	-	8x4.5x4.5	40	60.8	46	11.2	28	28
MR 15WN ZUE	16	9	42	9.5	40	23	8x4.5x4.5	60	56.9	38.5	13.1	20	45
MR 15WL ZUE	16	9	42	9.5	40	23	8x4.5x4.5	60	76	57.6	13.1	35	45

Load capacities are calculated according to ISO 14728. To compare the rating life definition and the load capacities:
 $C_{50B} = 1.26 \times C_{100B}$

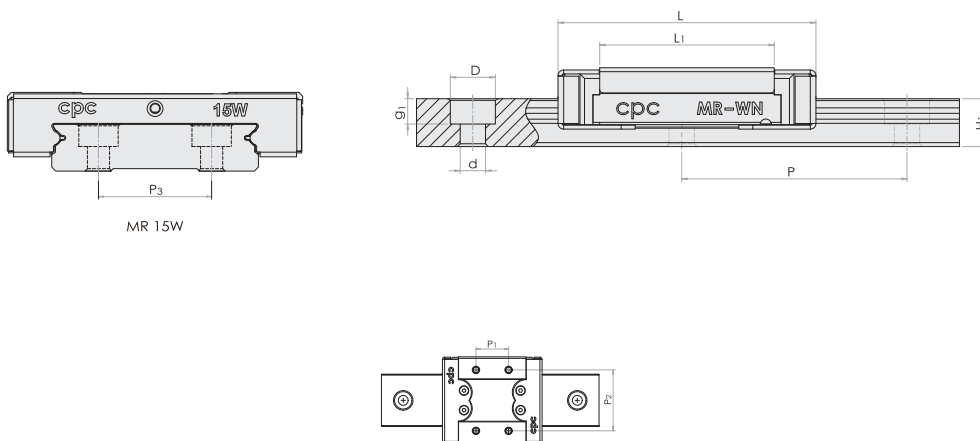

Block Dimension (mm)				Load Capacities (N)		Static Moment (Nm)			Weight		Size
M x g ₂	ø	S	T	C _{100B} (dyn)	C ₀ (stat)	M _{ro}	M _{po}	M _{yo}	Block (g)	Rail (g/m)	
M2x1.3	-	-	1.3	310	625	1.6	1.2	1.2	3.0	69	MR 2WL ZUE
M3x3	1.1	1.9	3.2	1180	2095	15	7.3	7.3	19	516	MR 7WN ZUE
M3x3	1.1	1.9	3.2	1570	3140	22.65	14.9	14.9	27	516	MR 7WL ZUE
M3x3	1.3	2.6	4	2030	3605	33.2	13.7	13.7	37	940	MR 9WN ZUE
M3x3	1.3	2.6	4	2550	4990	45.9	26.7	26.7	51	940	MR 9WL ZUE
M3x3.5	1.3	3.1	4.5	3065	5200	63.7	26.3	26.3	68	1472	MR 12WN ZUE
M3x3.5	1.3	3.1	4.5	4070	7800	95.6	56.4	56.4	96	1472	MR 12WL ZUE
M4x4.5	1.8	3.3	4.5	5065	8385	171.1	45.7	45.7	140	2818	MR 15WN ZUE
M4x4.5	1.8	3.3	4.5	6725	12580	257.6	93.1	93.1	203	2818	MR 15WL ZUE

MR-M SS Series

Standard Narrow Rail Type

(End seal)

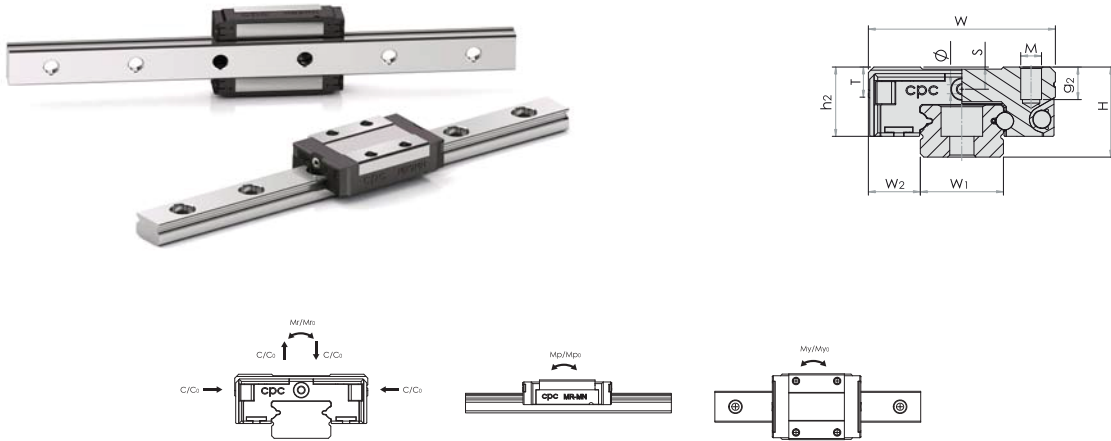

Size	Fabr. Dim.		Rail Dimension (mm)				Block Dimension (mm)					
	H	W ₂	W ₁	H ₁	P	D x d x g ₁	W	L	L ₁	h ₂	P ₁	P ₂
MRU 3MN SS	4	2.5	3	2.6	10	M1.6	8	11.7	6.8	3	3.5	-
MRU 3ML SS	4	2.5	3	2.6	10	M1.6	8	16	11	3	5.5	-
MR 5MN SS	6	3.5	5	3.5	15	3.5x2.4x1	12	16	10	4.5	-	8
MR 5ML SS	6	3.5	5	3.5	15	3.5x2.4x1	12	19.6	13.5	4.5	7	-
MR 7MN SS	8	5	7	4.7	15	4.2x2.4x2.3	17	24	14.3	6.5	8	12
MR 7ML SS	8	5	7	4.7	15	4.2x2.4x2.3	17	31.5	21.8	6.5	13	12
MR 9MN SS	10	5.5	9	5.5	20	6x3.5x3.5	20	30.8	20.5	7.8	10	15
MR 9ML SS	10	5.5	9	5.5	20	6x3.5x3.5	20	41	30.8	7.8	16	15
MR 12MN SS	13	7.5	12	7.5	25	6x3.5x4.5	27	35.4	22	10	15	20
MR 12ML SS	13	7.5	12	7.5	25	6x3.5x4.5	27	47.6	34.1	10	20	20
MR 15MN SS	16	8.5	15	9.5	40	6x3.5x4.5	32	43.1	27	12	20	25
MR 15ML SS	16	8.5	15	9.5	40	6x3.5x4.5	32	60.1	44	12	25	25

Load capacities are calculated according to ISO 14728. To compare the rating life definition and the load capacities:
 $C_{50B} = 1.26 \times C_{100B}$

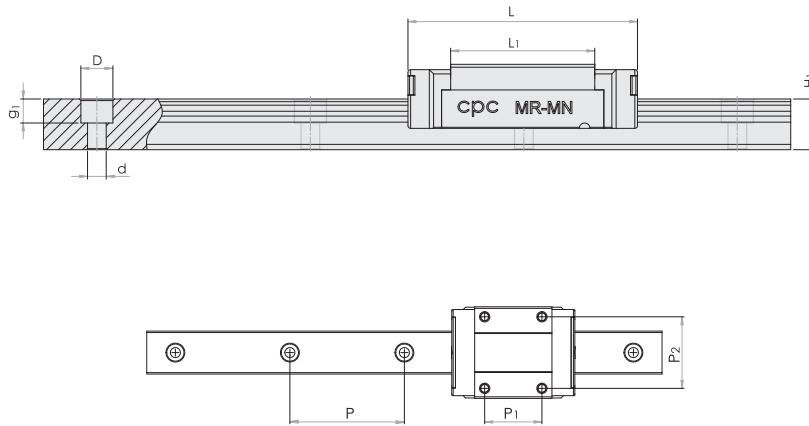

Block Dimension (mm)				Load Capacities (N)		Static Moment (Nm)			Weight		Size
M x g ₂	ø	S	T	C _{100B} (dyn)	C ₀ (stat)	M _{ro}	M _{po}	M _{yo}	Block (g)	Rail (g/m)	
M1.6x1.1	0.3	0.7	1.5	190	310	0.6	0.4	0.4	0.9	53	MRU 3MN SS
M2x1.1	0.3	0.7	1.5	295	575	0.9	1.1	1.1	1.2	53	MRU 3ML SS
M2x1.5	0.7	1.3	2	335	550	1.7	1	1	3.5	116	MR 5MN SS
M2.6x2.0	0.7	1.3	2	470	900	2.4	2.1	2.1	4	116	MR 5ML SS
M2x2.5	1.2	1.6	2.8	890	1440	5.2	3.3	3.3	8	215	MR 7MN SS
M2x2.5	1.2	1.6	2.8	1310	2440	9	7.7	7.7	14	215	MR 7ML SS
M3x3.0	1.3	2.2	3.3	1570	2495	11.7	6.4	6.4	18	301	MR 9MN SS
M3x3.0	1.3	2.2	3.3	2135	3880	18.2	12.4	12.4	28	301	MR 9ML SS
M3x3.5	1.4	3.2	4.3	2308	3465	21.5	12.9	12.9	34	602	MR 12MN SS
M3x3.5	1.4	3.2	4.3	3240	5630	34.9	30.2	30.2	51	602	MR 12ML SS
M3x5.5	1.9	3.3	4.3	3810	5590	43.6	27	27	61	930	MR 15MN SS
M3x5.5	1.9	3.3	4.3	5350	9080	70	63.3	63.3	90	930	MR 15ML SS

MR-W SS Series

Wide Rail Type

(End seal)

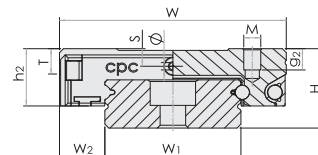

MR 2W-MR 12W

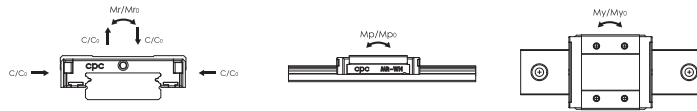

Size	Fabr. Dim.		Rail Dimension (mm)					Block Dimension (mm)					
	H	W ₂	W ₁	H ₁	P	P ₃	D x d x g ₁	W	L	L ₁	h ₂	P ₁	P ₂
MR 2WL SS*	4	3	4	2.6	10	-	2.8x1.8x1.0	10	17	11.9	3	6.5	-
MR 3WN SS*	4.5	3	6	2.7	15	-	4x2.4x1.5	12	15	10	3.5	4.5	-
MR 3WL SS*	4.5	3	6	2.7	15	-	4x2.4x1.5	12	20.1	15.1	3.5	8	-
MR 5WN SS	6.5	3.5	10	4	20	-	5.5x3x1.6	17	21.1	15.1	5	6.5	13
MR 5WL SS	6.5	3.5	10	4	20	-	5.5x3x1.6	17	27.2	21.2	5	11	13
MR 7WN SS	9	5.5	14	5.2	30	-	6x3.5x3.5	25	31.8	21.2	7	10	19
MR 7WL SS	9	5.5	14	5.2	30	-	6x3.5x3.5	25	40.5	30.1	7	19	19
MR 9WN SS	12	6	18	7.3	30	-	6x3.5x4.5	30	39.1	27.9	8.6	12	21
MR 9WL SS	12	6	18	7.3	30	-	6x3.5x4.5	30	50.7	39.4	8.6	24	23
MR 12WN SS	14	8	24	8.5	40	-	8x4.5x4.5	40	44.5	31.1	10.1	15	28
MR 12WL SS	14	8	24	8.5	40	-	8x4.5x4.5	40	59.6	46	10.1	28	28
MR 15WN SS	16	9	42	9.5	40	23	8x4.5x4.5	60	55.8	38.5	12	20	45
MR 15WL SS	16	9	42	9.5	40	23	8x4.5x4.5	60	74.5	57.6	12	35	45

* Anticipated

Load capacities are calculated according to ISO 14728. To compare the rating life definition and the load capacities:

$$C_{50B} = 1.26 \times C_{100B}$$

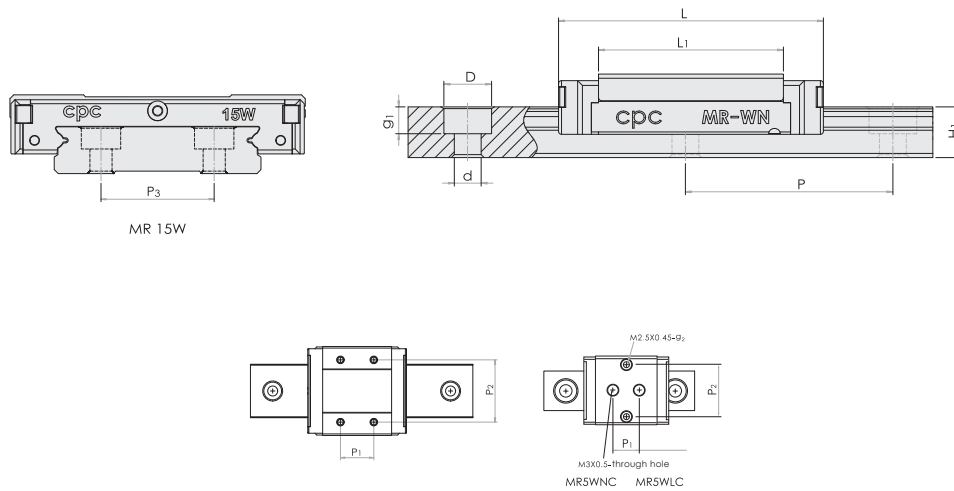

Block Dimension (mm)				Load Capacities (N)		Static Moment (Nm)			Weight		Size
M x g ₂	ø	S	T	C 100B (dyn)	C ₀ (stat)	M _{ro}	M _{po}	M _{yo}	Block (g)	Rail (g/m)	
M2x1.3	-	-	1.3	310	625	1.6	1.2	1.2	3.0	69	MR 2WL SS
M2x1.4	0.3	0.8	1.8	280	530	1.6	0.9	0.9	3.4	105	MR 3WN SS
M2x1.4	0.3	0.8	1.8	370	800	2.5	1.9	1.9	3.4	105	MR 3WL SS
M2.5x1.5	0.9	1.2	2.3	475	900	4.6	2.2	2.2	6	280	MR 5WN SS
M2.5x1.5	0.9	1.2	2.3	615	1315	6.8	4.1	4.1	8	280	MR 5WL SS
M3x3	1.1	1.9	3.2	1180	2095	15	7.3	7.3	19	516	MR 7WN SS
M3x3	1.1	1.9	3.2	1570	3140	22.65	14.9	14.9	27	516	MR 7WL SS
M3x3	1.3	2.6	4	2030	3605	33.2	13.7	13.7	37	940	MR 9WN SS
M3x3	1.3	2.6	4	2550	4990	45.9	26.7	26.7	51	940	MR 9WL SS
M3x3.5	1.4	3.1	4.5	3065	5200	63.7	26.3	26.3	65	1472	MR 12WN SS
M3x3.5	1.4	3.1	4.5	4070	7800	95.6	56.4	56.4	93	1472	MR 12WL SS
M4x4.5	1.9	3.3	4.5	5065	8385	171.1	45.7	45.7	137	2818	MR 15WN SS
M4x4.5	1.9	3.3	4.5	6725	12580	257.6	93.1	93.1	200	2818	MR 15WL SS

Standard MRU-M Series

Tapped from bottom

Size	Rail Dimensions (mm)			
	H ₁	W ₁	P	M ₁
MRU 3M	2.6	3	10	M1.6x0.35
MRU 5M	3.5	5	15	M3x0.5
MRU 7M	4.7	7	15	M3x0.5
MRU 9M	5.5	9	20	M4x0.7
MRU 12M	7.5	12	25	M4x0.7
MRU 15M	9.5	15	40	M4x0.7

Wide MRU-W Series

Tapped from bottom

Size	Rail Dimensions (mm)			
	H ₁	W ₁	P	M ₁
MRU 3W	2.7	6	15	M3x0.5
MRU 5W	4	10	20	M3x0.5
MRU 7W	5.2	14	30	M4x0.7
MRU 9W	7.3	18	30	M4x0.7
MRU 12W	8.5	24	40	M5x0.8
MRU 15W	9.5	42	40	M5x0.8

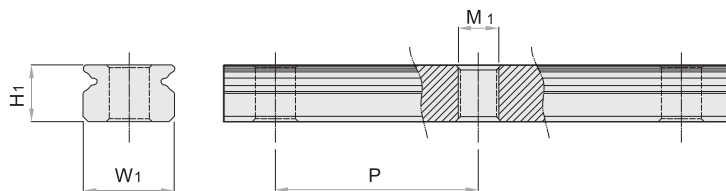

Linear Miniature Guides

MR U 15 M N - SS 2 - V1 P - 310L - 15 - 15 / J

Product type

MR: Miniature Linear Guide

Special rail

U: Threaded rail

Leave empty if standard

Rail dimension (width)

2, 3, 5, 7, 9, 12 or 15

Rail type

M: Standard width

W: Wide type

Block type

L: Long

N: Standard

Specifications

SS: with end seal

ZUE: end seal + bottom seal + reinforcement plate

+ lubrication storage

Block quantity

Quantity of runner blocks

Preload classes

V0: clearance

VS: standard

V1: light preload

Accuracy classes

N: Normal

H: High

P: Precision

Rail length (mm)

Starting hole pitch (mm)

End hole pitch (mm)

Customization code

Lubrication Injector

LUB - 01 - 18G

Lubricant

Type

- 00
- 01
- 02
- 03
- 04
- 05
- 11

Needle model

- 21G: 5M/5W
- 19G: 7M/7W
- 18G: 9M/9W
- 18G: 12M/12W
- 15G: 15M/15W

Length of Rail

Butt-jointing is required when lengths exceed Lmax. For more detailed information, please contact Rollco technical support.

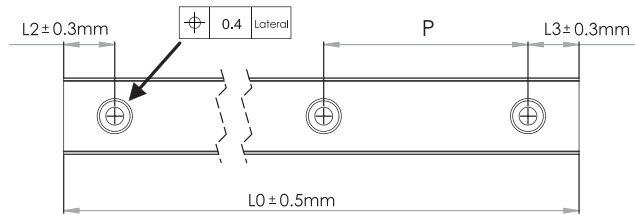

Standard Type

Size	Standard length of one rail	Pitch	L2, L3 min.	L2, L3 max.	L0 max.
3M	30 / 40 / 50	10	3	5	300
5M	40 / 55 / 70 / 85 / 100	15	3	10	1000
7M	Cut to length	15	3	10	1000
9M	Cut to length	20	4	20	1000
12M	Cut to length	25	4	20	1000
15M	Cut to length	40	4	35	1000

Wide Type

Size	Standard length of one rail	Pitch	L2, L3 min.	L2, L3 max.	L0 max.
2W	30 / 40 / 50	10	3	5	300
3W	40 / 55 / 70	15	3	10	1000
5W	Cut to length	20	4	15	1000
7W	Cut to length	30	3	25	1000
9W	Cut to length	30	4	25	1000
12W	Cut to length	40	4	35	1000
15W	Cut to length	40	4	35	1000

Precision

Accuracy

MR miniature linear guide series have three accuracy grades (P,H,N) for your choice.

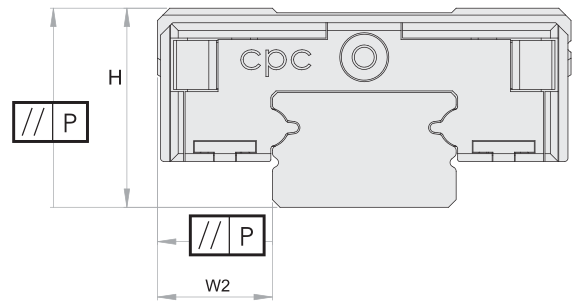

Accuracy grades (µm)

		Precision P	High H	Normal N
Admissible height H dimension Tolerance	H	± 10	± 20	± 40
Height variation for different runner blocks on the same rail position	ΔH	7	15	25
Admissible width W dimension tolerance	W2	± 15	± 25	± 40
Width variation for different runner blocks on the same rail position	ΔW2	10	20	30

Speed

The maximum speed for the standard MR-SS type is:
Vmax = 3 m/s

Maximum acceleration:

amax = 250 m/s²

(If preload is at V0, capability of reaching 40m/s²)

The maximum speed for the standard MR-ZUE type is:

Vmax = 5 m/s

Maximum acceleration **amax = 300 m/s²**

(If preload is at V0, capable of reaching 60m/s²)

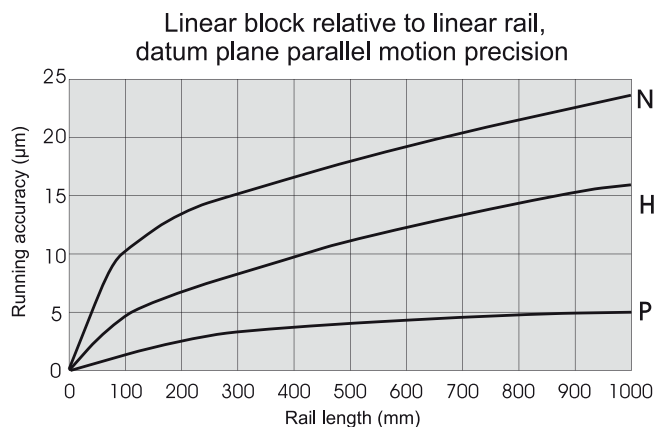

Preload

The MR Miniature Linear Guide series has three degrees of preload capacity: V0, VS and V1 (as described in the preload table below). Appropriate preload levels can enhance the stiffness, precision, and torsion resistance performance of the linear guide. But an inappropriate application thereof can also negatively affect the product life and its motional resistance levels.

Preload type	Model code	Clearance (µm)						Application
		3	5	7	9	12	15	
Clearance	V0	+3 - 0	+3 - 0	+4 - 0	+4 - 0	+5 - 0	+6 - 0	Very smooth
Standard	VS	+1 - 0	+1 - 0	+2 - 0	+2 - 0	+2 - 0	+3 - 0	Smooth and high precision
Light preload	V1	0 - -0.5	0 - -1	0 - -3	0 - -4	0 - -5	0 - -6	High rigidity Minimizes vibration High precision Load balance

Operating Temperature

The MR Miniature Linear Guide can operate in a range of temperatures from -40°C~ + 80°C. For short term operation, it can reach up to +100°C.

Lubrication

Function

When operating the linear guide under sufficient lubrication conditions, a one-micron layer of oil forms at the contact zone, separating the loaded rolling components and the raceway.

Sufficient lubrication will:

- Reduce friction
- Reduce wear
- Reduce corrosion
- Dissipate heat and increase service life

Lubrication Caution

- ZUE Lubrication Storage block
 1. The block already contains lubricants which can be directly installed on the machine, without the need for additional washing.
 2. When first washing the blocks, please do not soak them in the lubricant before both the detergent and cleaning naphtha within are totally dry. The block is ready for installation only after the lubrication storage is full of the lubricant.
- The linear guide must be lubricated for protection before first time use. Contaminants of any kind, weather liquid or solid, should be avoided.
- The runner block should be moved back and forth during lubrication.
- The lubricant can be added either manually or automatically directly onto the rail raceway.
- The lubricant can be injected into the lubrication holes on either end of the runner block.
- A thin layer of observable lubricant should be maintained on the surface of the rail .
- Re-lubrication must be completed before contamination or discoloration of the lubricant occurs.
- Please notify us if product is intended for use in acidic, alkaline, or clean room applications.
- Please contact Rollco technical department for lubrication assistance if the runner block is intended for use in a wall mount configuration.
- The re-lubrication interval must be shortened if the travel stroke is < 2 or > 15 times the length of the steel body of the runner block.

Grease Lubrication

When grease lubrication is applied, we recommend synthetic oil-based lithium soap grease with a viscosity between ISO VG32-100.

Oil Lubrication

For oil lubrication, we recommend synthetic oils CLP, CGLP (based on DIN 51517) or HLP (based on DIN 51524) with a viscosity range of between ISO VG32-100 and a working temperature range between 0°C~+70°C. We recommend ISO VG10 for use in lower temperature environments.

Re-lubrication

- Re-lubrication shall be applied before the lubricant in the block is contaminated or changes color.
- The amount of the lubricant applied should be 1/2 of the first lubrication. When applying lubricant, this should be done until it seeps out from the device.
- Re-lubrication shall be applied under steady operating temperature, with the runner block moved back and forth throughout for optimum distribution.
- If the stroke is smaller than twice or greater than 15 times the steel body length of the block, the re-lubrication interval shall be shortened.

Model code	First lubrication (cm ³)
-	-
3 MN	0.02
3 ML	0.03
5 MN	0.03
5 ML	0.04
7 MN	0.12
7 ML	0.16
9 MN	0.23
9 ML	0.30
12 MN	0.41
12 ML	0.51
15 MN	0.78
15 ML	1.05

Model code	First lubrication (cm ³)
2 WL	0.03
3 WN	0.03
3 WL	0.04
5 WN	0.04
5 WL	0.05
7 WN	0.19
7 WL	0.23
9 WN	0.30
9 WL	0.38
12 WN	0.52
12 WL	0.66
15 WN	0.87
15 WL	1.11

Re-lubrication Interval

The re-lubrication interval depends on individual use, as the speed, load, stroke length and operating environment are all factors. Careful observation of rails and blocks is the basis to determine the optimal re-lubrication interval; as a rule of thumb, re-lubricate at least once per year. Do not apply water-based coolant liquid on the linear rails or slide. Inject lubricant through injection holes on both ends of the runner block with the recommended cpc brand injector.

Lubrication Grease

- 00 For general applications
- 01 For low-friction, low-noise applications
- 02 For clean room applications
- 03 For clean room and vacuum environment applications
- 04 For high-speed applications
- 05 For micro-oscillation applications

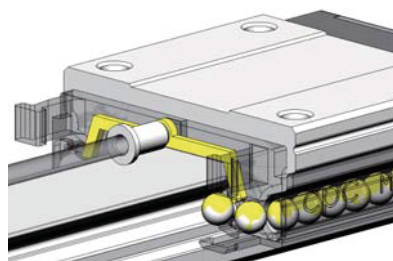

Lubrication Oil

- 11 For general applications, ISO V32-68

Lubricant amount: 10ml



Friction

The MR Miniature Linear Guide Series has low-friction characteristics with a stable and minor starting friction.

Sealing Design

The MR Miniature Linear Guide Series are enclosed by end seals on both ends of the runner block. Optional side seals can also create an all-around sealing system.

MR size	Friction of end seal under lubrication		Friction	
	M	W		
2	0.08	0.2		
3	0.08	0.2	$F_m = \mu \cdot F$	____(1)
5	0.08	0.2	F	Load (N)
7	0.1	0.4	F_m	Friction (N)
9	0.1	0.8		
12	0.4	1.0		
15	1.0	1.0		

The MR Miniature Linear Guide Series friction factor is app $\mu = 0.002\sim 0.003$

Friction Factors

- Sealing system.
- Collision between the balls during operation.
- Collision between the balls and the return path.
- Number of balls in the gothic arch load zone.
- Resistance from lubricant to ball pressure.
- Resistance caused by contaminants.

Load Capacity and Rating Life

Static Load Rating C_0

Measuring the static load of the travel force along the acting direction, the maximum stress between the rolling balls and raceway is as follows:

If the curvature radius is lower or equal to 0.52: 4200 MP

If the curvature radius is equal or higher to 0.6: 4600 MP

Note: Under maximum stress levels, a permanent deformation will be generated at the contact point. This corresponds roughly to about 0.0001 times the rolling element diameter. (The above is according to ISO 14728-2)

Static load safety factor calculation			
Operation condition	S_0	$S_0 = C_0 / P_0$	____(11)
Normal operation	1 – 2	$S_0 = M_0 / M$	____(12)
Load with vibration or impact	2 – 3	$P_0 = F_{max}$	____(13)
High accuracy and smooth running	≥ 3	$M_0 = M_{max}$	____(14)

Static Load P_0 and Moment M_0

The permissible static and applied static load of the MR Miniature Linear Guide Series is limited by:

- The static load of the linear guide.
- The permissible load of fixed screws.
- The permissible load for the connected parts of the mechanism.
- The static load safety factor required for the application.

The equivalent static load and static torque are the largest load and torque, please consult with formulas (13) and (14).

Static Load Safety Factor S_0

In order for the linear bearing to permanently withstand potential deformation while delivering a guaranteed accuracy and reliable motion, the static load safety factor should be calculated with formulas (11) and (12).

- S_0 static load safety factor
 C_0 basic static load in acting direction N
 P_0 equivalent static load in acting direction N
 M_0 basic static moment in acting direction Nm
 M equivalent static moment in acting direction Nm

Dynamic Load Rating C_{100B}

For constant sized and directional loads, when the linear bearing is under such a load, the rating life of a linear guide can reach a theoretical travel distance of 100km. (The above is according to ISO 14728-1.)

Rating life calculation

	L	= rating life for 100,000 meter travel distance (m)
$C_{50B} = 1.26 \cdot C_{100B}$ _____(2)	L_h	= rating life in hours (h)
$C_{100B} = 0.79 \cdot C_{50B}$ _____(3)	C_{100B}	= dynamic load rating (N)
$L = \left(\frac{C_{100B}}{P}\right)^3 \cdot 10^5$ _____(4)	P	= equivalent load (N)
$L_h = \left(\frac{L}{2 \cdot s \cdot n \cdot 60}\right) = \left(\frac{L}{v_m \cdot 60}\right)$ _____(5)	s	= length of stroke (m)
	n	= stroke repetition (min^{-1})
	v_m	= average speed (m/min)

Rating Life L

90% survival rate for an individual linear guide or a batch of identical linear guides in standard product material and operation conditions is calculated as above (according to ISO 14728-1 standards). When using the 50km travel standard, the dynamic load rating will exceed the ISO 14728-1 standard value by 20% or more. Formula (2) describes the relationship between the two load ratings.

Calculation of Rating Life

Formulas (4) and (5) can be used when the equivalent dynamic load and the average speeds are constant.

Equivalent Dynamic Load and Speed

If the load and speed are not constant, it is important to take into account the actual load and speed as both will influence life expectancy.

Equivalent Dynamic Load

If there is a change in load only, the equivalent dynamic load can be calculated according to formula (6).

Equivalent Speed

If there is a change in speed only, the equivalent speed can be calculated according to formula (7). If there are changes in both load and speed, the equivalent dynamic load can be calculated according to formula (8).

Equivalent load capacities and speed calculation	
$P = 3 \sqrt{\frac{q_1 \cdot F_1^3 + q_2 \cdot F_2^3 + \dots + q_n \cdot F_n^3}{100}} \quad \text{---(6)}$	P = Equivalent dynamic load (N)
$\bar{v} = \frac{q_1 \cdot v_1 + q_2 \cdot v_2 + \dots + q_n \cdot v_n}{100} \quad \text{---(7)}$	q = Percentage of stroke (%)
$P = 3 \sqrt{\frac{q_1 \cdot v_1 \cdot F_1^3 + q_2 \cdot v_2 \cdot F_2^3 + \dots + q_n \cdot v_n \cdot F_n^3}{100 \cdot \bar{v}}} \quad \text{---(8)}$	F ₁ = Discrete load steps (N)
$P = F_X + F_Y \quad \text{---(9)}$	\bar{v} = Average speed (m/min)
$P = F + M \cdot \frac{C_0}{M_0} \quad \text{---(10)}$	v = Discrete speed steps (m/min)
	F = External dynamic load N
	F _Y = External dynamic load, vertical N
	F _X = External dynamic load, horizontal N
	C ₀ = Static load rating N
	M = Static moment Nm
	M ₀ = Static moment in direction of action Nm

Combined Equivalent Dynamic Load

If the linear guide bears the load from arbitrary angles so that the acting force does not conform to horizontal and vertical directions, its equivalent dynamic load is calculated as shown on formula (9).

Under the Condition with the Moment

If the linear guide bears the load and the moment simultaneously, its equivalent dynamic load is calculated with formula (10). According to ISO 14728-1, when equivalent dynamic load tolerance rates below 0.5C₀/P, a reliable product life value can be calculated.

Single Block Bearing the Moment

For a given structure, if the block needs to bear torque moments from M_p and M_y directions, the maximum moment that the block can withstand while still maintain smooth running conditions measures at about 0.3-0.1 times the static moment rating. The higher the preload, the higher the loading value and vice versa.

In the case of any design questions, please contact Rollco.

Line Chart

Under pressure

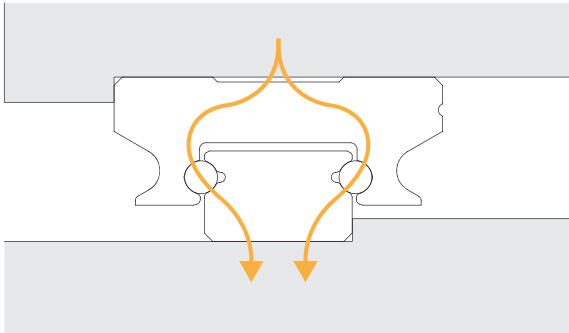

Figure A

Pull up

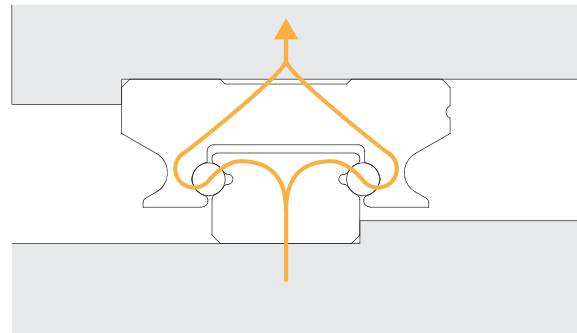

Figure B

Lateral force 1

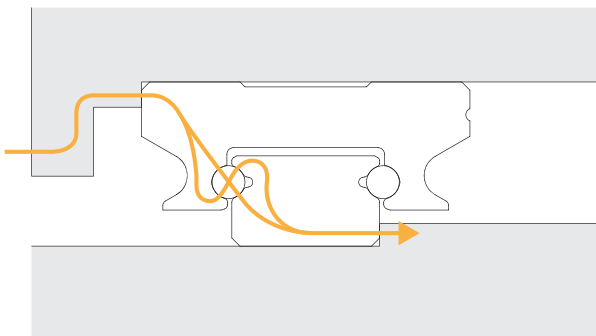

Figure C

Lateral force 1

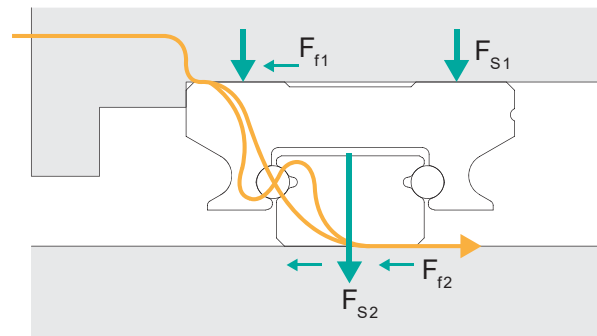

Figure D

F_{S1} 、 F_{S2} :screw fixation
 F_{f1} 、 F_{f2} :frictional resistance
 $F_f = F_s \cdot \mu_0$

As can be seen from the three diagrams in Figure A to Figure D, when subjected to upward, downward and lateral loads, the force flow will be distributed to the two ball transfer.

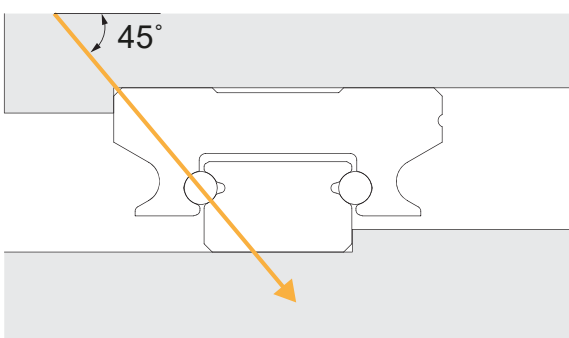

Figure E

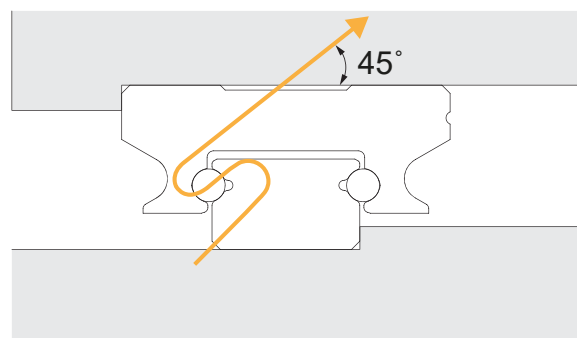

Figure F

As shown in the two diagrams in Figures E and F, the load acting on the 45-degree angle has the greatest effect on the system's life because the transfer of force is limited to a single row of balls.

When the load is applied horizontally or vertically (0°, 90°, 180°, 270°), the equivalent load of the slide is equal to the actual load. When the load angle is 45°, its equivalent load is approximately 1.414 times that of the main direction.

When the same load is at different angles, the comparison of equation and the actual equivalence load is as shown in the following figure.

Therefore, in order to increase the service life of the linear system, it should be installed in the appropriate direction to bear the load. Otherwise, the service life will be greatly reduced, as shown in the figure below. Since the relationship between life and load is as the power of formula (8), when the acceptance angle is 45°, the service life will be significantly reduced.

The following is the life L comparison chart (in %) for different angles under the same load.

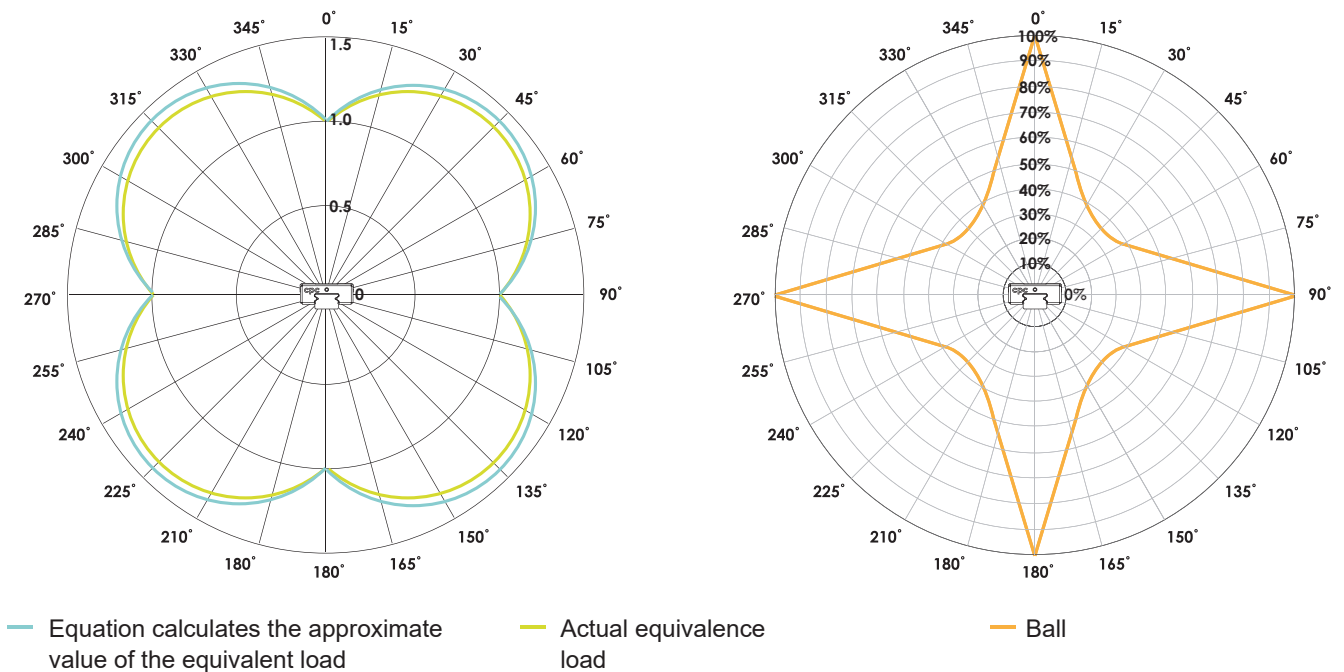

Customization Requirements

The meaning of suffix characters:

- J** = Slide rail connection
- G** = Customer designated lubricant
- I** = With Inspection report
- R** = Special process for rail
- B** = Special processing for block
- S** = Special straightness requirements for rail
- C3** = Cap M3
- C4** = Cap M4

J: Slide rail connection

When the required length of rail exceeds the standard rail length, a butt-joint can be specified. The rail butt-joint indication is marked as illustrated below.

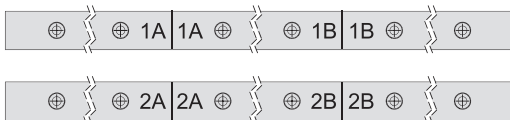

G: Customer designated lubricant

According to application environment.

GN: No lubricant

GC: Low dust generation

Suitable for clean room environments.

I: With Inspection report

Please contact technical support.

R: Special process for rail

For special process requirements, please contact Rollco technical support.



B: Special processing for block

For special process requirements, please contact technical support.

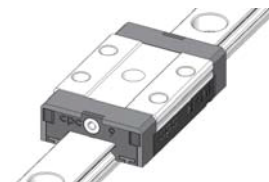

S: Special straightness requirements for rail

The straightness of the linear guide rail is specially calibrated by precision fine grinding.

C3: CapM3

Applies to MR9M, MR12M, MR15M, MR7W & MR9W rails.

C4: CapM4

Applies to MR12W, MR15W rails.

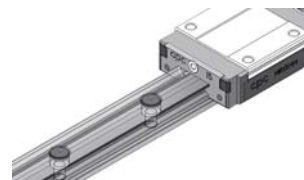

Installation Instructions

Height and Chamfer of Reference Edge

To avoid interference, the corner of the reference edge should have a chamfer. If not, please refer to the following table for the height of the reference edge corner and the height of the reference edge.

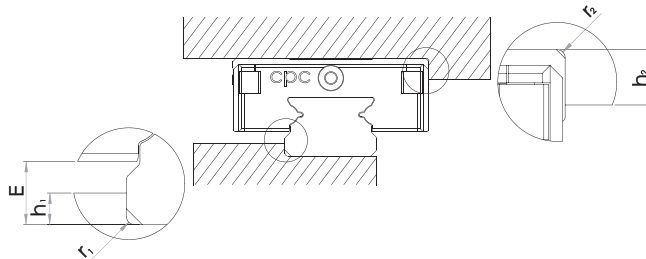

Height and chamfer of the reference surface

Size	h2	r2max	r1max	h1	SS		ZUE	
					E	h1	E	
3M	1.5	0.3	0.1	0.8	1	-	-	
5M	1.9	0.3	0.2	1.1	1.3	0.7	1.0	
7M	2.8	0.3	0.2	1.2	1.4	-	-	
9M	3	0.3	0.2	1.8	2.1	1.1	1.5	
12M	4	0.5	0.3	2.6	2.9	1.7	2.1	
15M	4.5	0.5	0.3	3.6	3.9	2.4	2.9	

Size	h2	r2max	r1max	h1	SS		ZUE	
					E	h1	E	
2WL	1.5	0.3	0.1	0.6	0.8	0.4	0.6	
3W	1.7	0.3	0.1	0.4	0.6	-	-	
5W	2	0.3	0.2	1.2	1.4	-	-	
7W	2.8	0.3	0.2	1.7	1.9	1.1	1.4	
9W	3	0.3	0.2	3	3.3	2.2	2.6	
12W	4	0.5	0.3	3.5	3.7	2.4	2.8	
15W	4.5	0.5	0.3	3.5	3.7	2.4	2.8	

Screw tightening torque (Nm)

Screw grade 12.9 Alloy Steel Screw	Steel	Cast Iron	Non Iron Metal	SO 3506-1 A2-70 Stainless Screw	Cast Iron
	M2	0.6	0.4		0.3
M2.5/M2.6	1.2	0.8	0.6	M2	0.3
M3	1.8	1.3	1	M2.5/M2.6	0.6
M4	4	2.5	2	M3	1.1
				M4	2.5

The mounting surface

The mounting surface should be ground or fine milled to reach a surface roughness of Ra1.6 μm.

Geometric and Positional Accuracy of the Mounting Surface

Inaccurate mounting surfaces will affect the operational accuracy of the linear guide when the mounting surface height differential is greater than the values calculated by formulas (15), (16), and (17). The rating lifetime will also be shortened.

$$e1 \text{ (mm)} = b \text{ (mm)} \cdot f1 \cdot 10^{-4} \quad \text{---(15)}$$

$$e2 \text{ (mm)} = d \text{ (mm)} \cdot f2 \cdot 10^{-4} \quad \text{---(16)}$$

$$e3 \text{ (mm)} = f3 \cdot 10^{-3} \quad \text{---(17)}$$

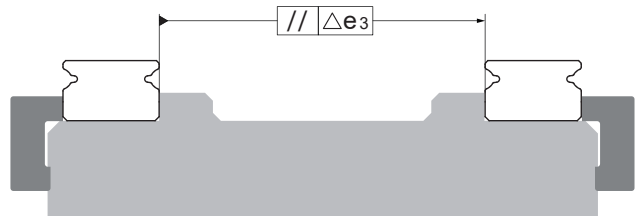

Reference Edge

Rail: Both sides of the track rail can serve as the reference edge without any special marking. Block: Reference edge is opposite to the groove marking side.

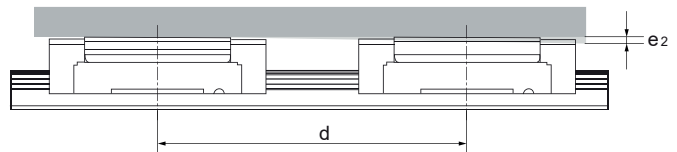
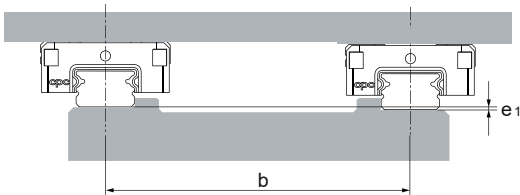

Size	V0/VS			V1		
	f1	f2	f3	f1	f2	f3
3MN	4	9	2	3	9	1
5MN	4	8	2	2	8	2
7MN	5	11	4	3	10	3
9MN	5	11	6	4	10	4
12MN	6	13	8	4	12	6
15MN	7	11	12	5	10	8
3ML	4	5	2	3	5	1
5ML	3	5	2	2	5	1
7ML	4	6	4	3	6	3
9ML	5	7	5	3	7	4
12ML	5	8	8	3	7	5
15ML	7	8	11	4	8	7

Size	2V0/VS			V1		
	f1	f2	f3	f1	f2	f3
2WL	4	5	2	3	5	1
3WN	2	5	2	4	3	1
5WN	2	5	2	1	3	1
7WN	2	6	4	2	4	3
9WN	2	7	6	2	5	4
12WN	3	8	8	2	5	5
15WN	2	9	11	1	6	7
3WL	2	3	1	1	2	1
5WL	2	3	2	1	2	1
7WL	2	4	4	1	3	3
9WL	2	5	5	2	3	3
12WL	2	5	7	2	3	5
15WL	2	5	10	1	4	7

Rollco Products



COMPACT RAIL

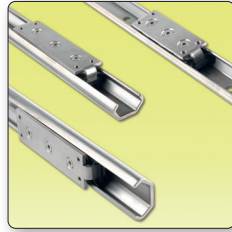

C-RAIL

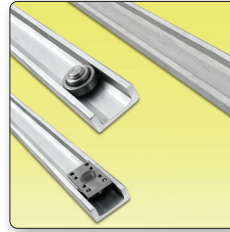

U-RAIL

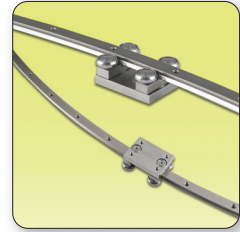

CURVI LINE



LINEAR RAIL SBI

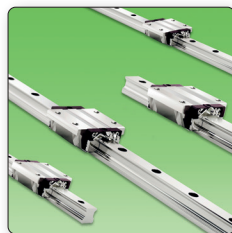

**LINEAR RAIL
BALL CHAIN**

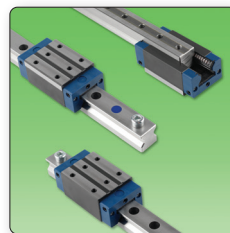

**LINEAR ROLLER
GUIDE**

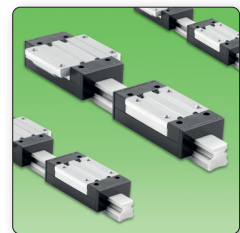

**LINEAR RAIL
ALUMINIUM**

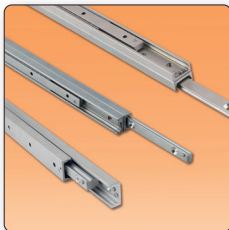

**TELESCOPIC RAIL
HEAVY**



**TELESCOPIC RAIL
LIGHT**

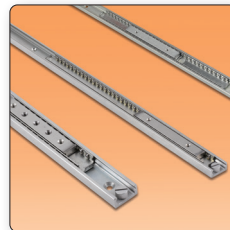

EASYSLIDE

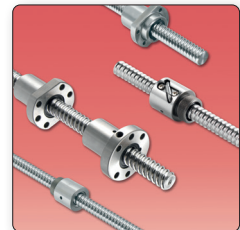

BALL SCREWS

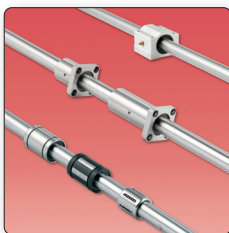

**BALL BEARINGS
& STEEL SHAFTS**



LINEAR UNIT RHL

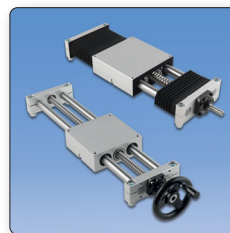

LINEAR UNIT QME



LINEAR UNIT E-SMART

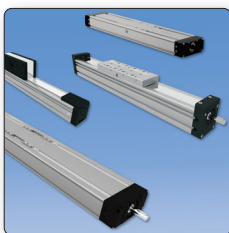

LINEAR UNITS CT & MT

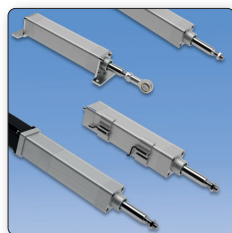

**PNCE ELECTRO-
MECHANICAL CYLINDERS**



ALUMINIUM PROFILES



BELT CONVEYORS

Rollco AB
Box 22234
Ekvändan 17
250 24 Helsingborg
Sweden
Tel. +46 42 150040
www.rollco.se

Rollco A/S
Skomagervej 13 E
7100 Vejle
Denmark
Tel. +45 7552 2666
www.rollco.dk

Rollco Oy
Sarankulmankatu 12
33900 Tampere
Finland
Tel. +358 207 57 97 90
www.rollco.fi

Rollco Norge AS
Industrigata 6
3414 Lierstrada
Norway
Tel. +47 32 84 00 34
www.rollco.no

Rollco Taiwan
No. 28, Lane 125, Da-an Road
Shulin District 238
New Taipei City, Taiwan
Tel. +886-2-8687-2726
Fax +886-2-8687-2720
www.rollco-tw.com

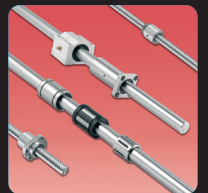
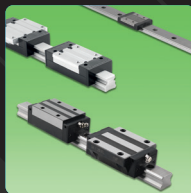

ROLLCO
SPECIALIZED
ON LINEAR MOTION