

MGTB

The MGTB is a toothed belt driven mini linear unit where the rotary motion (rotation) of the drive shaft is converted to the linear motion (translation) of the carriage with high mechanical efficiency and low internal friction.

High-performance features such as high speed, good positioning accuracy, and high repeatability are ensured through a zero-backlash toothed belt drive and a linear guiding system.

A preassembled standard motor (with a motor adapter and a coupling) together with the standard drive, makes the system plug and drive ready. Compact dimensions and optimally selected motor combinations cover a wide range of applications.

Options, such as different motor sizes, together with a wide range of accessories and possible multi-axis system combinations make this product highly flexible.

□ = Square cross section

Dimensions in mm.

For other CAD files, please contact Rollco.

Ambient Temperature (°C): 0 °C ~ +50 °C

Ambient Temperature without a Motor (°C): 0 °C ~ +60 °C

Protection Class: IP40

Duty Cycle: 100 %

Maintenance: Life-time pre-lubricated



MGTB with motor and motor adapter VK

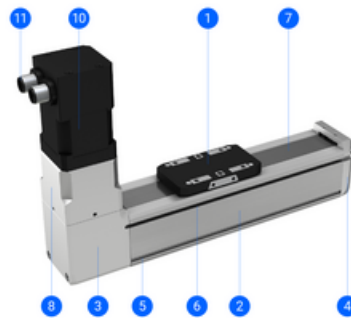

1. Carriage
2. Aluminium profile
3. Drive block with a pulley
4. End block
5. Mounting slots
6. Slot for the magnetic field sensors
7. Corrosion-resistance protection strip
8. Motor adapter VK with a coupling
10. Preassembled motor (with/without a brake)
11. Standard connectors (motor, encoder and brake - optionally)

MGTB

MGTB without motor

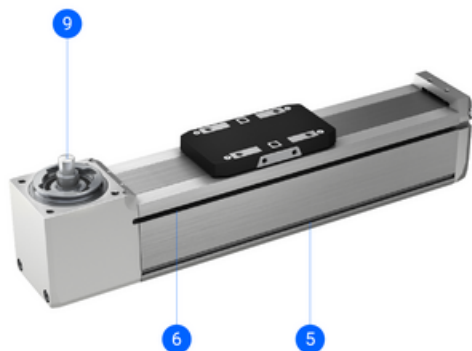

- 5. Mounting slots
- 6. Slot for the magnetic field sensors
- 9. The drive shaft of the pulley

General Data

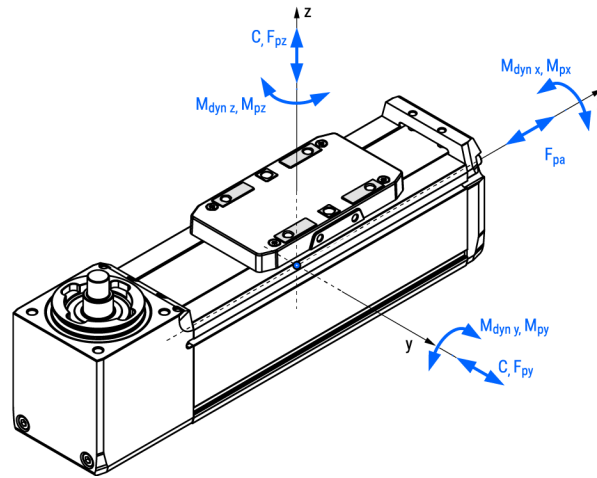

Designation	Description	Dynamic Load Capacity C (N)	Dynamic Moment Mx (Nm)	Dynamic Moment My (Nm)	Dynamic Moment Mz (Nm)
MGTB 32	Without a motor	1310	4.8	4.1	4.1
MGTB 32 - VK - 42	With motor size 42 and motor adapter VK	1310	4.8	4.1	4.1
MGTB 45	Without a motor	3240	20.1	17.4	17.4
MGTB 45 - VK - 42	With motor size 42 and motor adapter VK	3240	20.1	17.4	17.4
MGTB 45 - VK - 56	With motor size 56 and motor adapter VK	3240	20.1	17.4	17.4
MGTB 60	Without a motor	11190	77.4	79.8	79.8
MGTB 60 - VK - 56	With motor size 56 and motor adapter VK	11190	77.4	79.8	79.8
MGTB 60 - VK - 86	With motor size 86 and motor adapter VK	11190	77.4	79.8	79.8

Designation	Max. Permissible Loads Forces Fpy (N)	Max. Permissible Loads Forces Fpz (N)	Max. Permissible Loads Moments Mpx (Nm)	Max. Permissible Loads Moments Mpy (Nm)	Max. Permissible Loads Moments Mpz (Nm)	Max. Repeatability (mm)
MGTB 32	200	300	2.0	1.8	1.3	± 0.08
MGTB 32 - VK - 42	200	300	2.0	1.8	1.3	± 0.08
MGTB 45	400	700	7.4	6.3	4.7	± 0.08
MGTB 45 - VK - 42	400	700	7.4	6.3	4.7	± 0.08
MGTB 45 - VK - 56	400	700	7.4	6.3	4.7	± 0.08
MGTB 60	850	2000	29.2	30.8	31.8	± 0.08
MGTB 60 - VK - 56	850	2000	29.2	30.8	31.8	± 0.08
MGTB 60 - VK - 86	850	2000	29.2	30.8	31.8	± 0.08

General Data

Designation	Absolute Stroke
MGTB 32	100, 200, 300, 400, 500, 600, 700, 800, 1000, 1200, 1400, 1600
MGTB 32 - VK - 42	100, 200, 300, 400, 500, 600, 700, 800, 1000, 1200, 1400, 1600
MGTB 45	100, 200, 300, 400, 500, 600, 700, 800, 1000, 1200, 1400, 1600
MGTB 45 - VK - 42	100, 200, 300, 400, 500, 600, 700, 800, 1000, 1200, 1400, 1600
MGTB 45 - VK - 56	100, 200, 300, 400, 500, 600, 700, 800, 1000, 1200, 1400, 1600
MGTB 60	100, 200, 300, 400, 500, 600, 700, 800, 1000, 1200, 1400, 1600, 1800, 2000
MGTB 60 - VK - 56	100, 200, 300, 400, 500, 600, 700, 800, 1000, 1200, 1400, 1600, 1800, 2000
MGTB 60 - VK - 86	100, 200, 300, 400, 500, 600, 700, 800, 1000, 1200, 1400, 1600, 1800, 2000

Dimensions

MGTB without motor

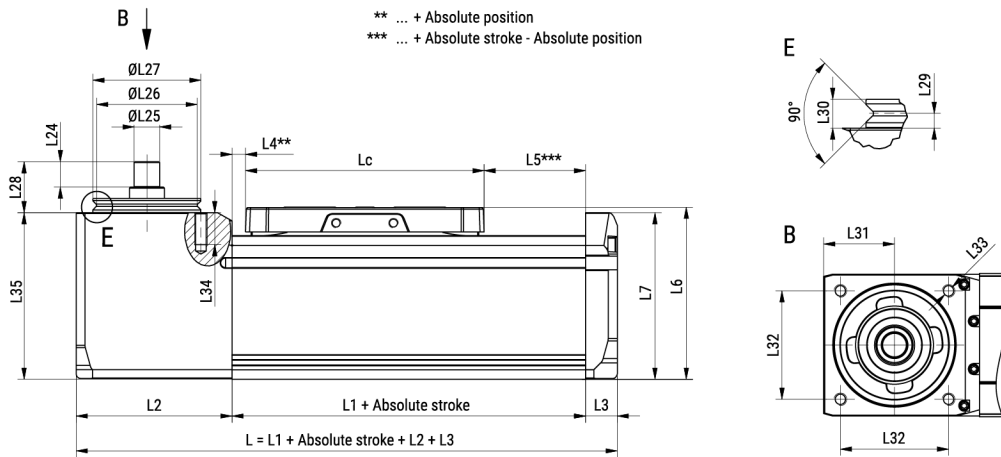

MGTB with motor and motor adapter VK

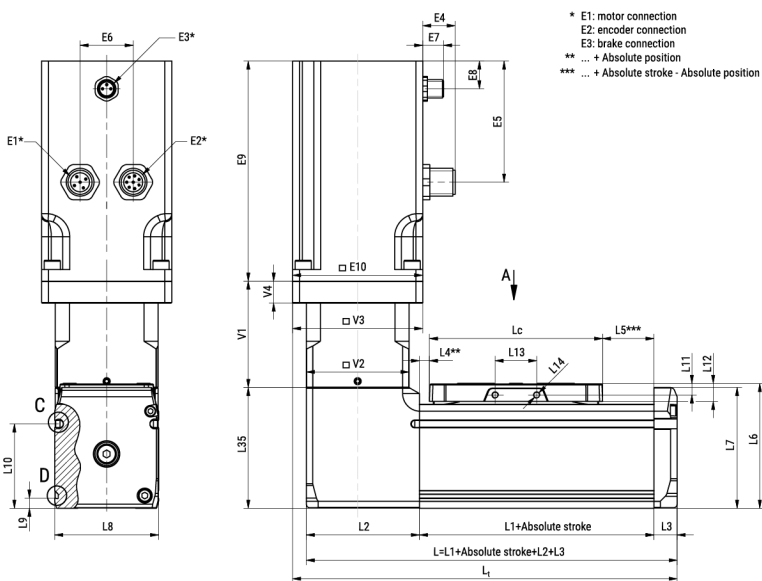

MGTB with motor and motor adapter VK

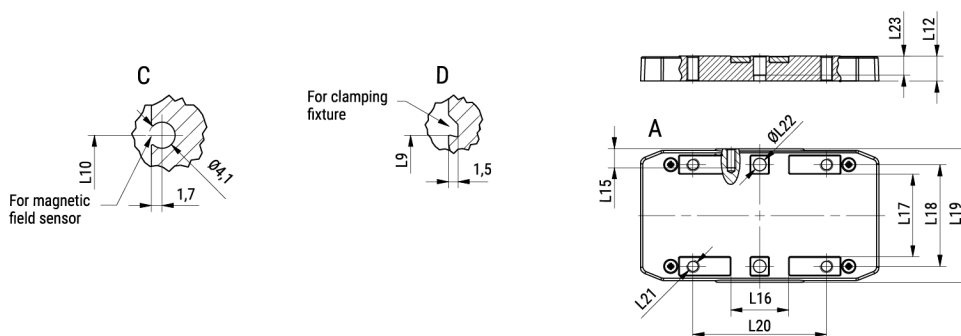

Dimensions

Absolute stroke of the MGTB definition

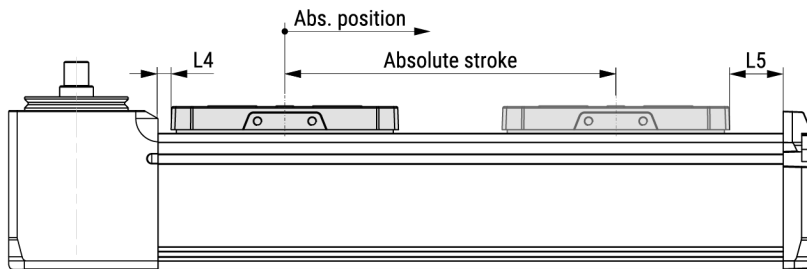

Designation	Lc	L1	L2	L3	L4	L5	L6	L7	L8
MGTB 32	65	104	32.75	8	2.5	36.5	38.5	35.75	32
MGTB 32 - VK - 42	65	104	32.75	8	2.5	36.5	38.5	35.75	32
MGTB 45	75	124	49	10	4.3	44.7	54	52.25	45
MGTB 45 - VK - 42	75	124	49	10	4.3	44.7	54	52.25	45
MGTB 45 - VK - 56	75	124	49	10	4.3	44.7	54	52.25	45
MGTB 60	90	139	64	12	3.2	45.8	72	68.75	60
MGTB 60 - VK - 56	90	139	64	12	3.2	45.8	72	68.75	60
MGTB 60 - VK - 86	90	139	64	12	3.2	45.8	72	68.75	60

Designation	L9	L10	L11	L12	L13	L14	L15	L16	L17	L18
MGTB 32	4.4	23.7	4	5.9	18	M2	4	14.6	18.4	22.5
MGTB 32 - VK - 42	4.4	23.7	4	5.9	18	M2	4	14.6	18.4	22.5
MGTB 45	4.4	36.5	5	7.8	18	M3	6	18.6	16.4	32
MGTB 45 - VK - 42	4.4	36.5	5	7.8	18	M3	6	18.6	16.4	32
MGTB 45 - VK - 56	4.4	36.5	5	7.8	18	M3	6	18.6	16.4	32
MGTB 60	4.4	45	6	11	30	M4	6	25.4	38.4	45
MGTB 60 - VK - 56	4.4	45	6	11	30	M4	6	25.4	38.4	45
MGTB 60 - VK - 86	4.4	45	6	11	30	M4	6	25.4	38.4	45

Designation	L19	L20	L21	L22	L23	L24	L25	L26	L27	L28
MGTB 32	30	35	M3	2 (H7)	5	7	5 (h7)	22.6	25 (h7)	14
MGTB 32 - VK - 42	30	35	M3	2 (H7)	5	7	5 (h7)	22.6	25 (h7)	14
MGTB 45	42	42	M4	4 (H7)	6	8	8 (h7)	31.6	34 (h7)	16
MGTB 45 - VK - 42	42	42	M4	4 (H7)	6	8	8 (h7)	31.6	34 (h7)	16
MGTB 45 - VK - 56	42	42	M4	4 (H7)	6	8	8 (h7)	31.6	34 (h7)	16
MGTB 60	57	55	M5	5 (H7)	8	10	10 (h7)	39.6	42 (h7)	20
MGTB 60 - VK - 56	57	55	M5	5 (H7)	8	10	10 (h7)	39.6	42 (h7)	20
MGTB 60 - VK - 86	57	55	M5	5 (H7)	8	10	10 (h7)	39.6	42 (h7)	20

Designation	L29	L30	L31	L32	L33	L34	L35	V1	V2	V3
MGTB 32	2.3	4.5	15.75	24.5	M3	3	37.75	-	-	-

Dimensions

Designation	L29	L30	L31	L32	L33	L34	L35	V1	V2	V3
MGTB 32 - VK - 42	2.3	4.5	15.75	24.5	M3	3	37.75	40	31.5	42
MGTB 45	2.3	4.5	22.25	34	M4	10	54.85	-	-	-
MGTB 45 - VK - 42	2.3	4.5	22.25	34	M4	10	54.85	42	44.5	44.5
MGTB 45 - VK - 56	2.3	4.5	22.25	34	M4	10	54.85	46	44.5	56.4
MGTB 60	2.3	4.5	29.75	48	M5	10	72.50	-	-	-
MGTB 60 - VK - 56	2.3	4.5	29.75	48	M5	10	72.50	52.5	59.5	59.5
MGTB 60 - VK - 86	2.3	4.5	29.75	48	M5	10	72.50	69	59.5	86

Designation	V4	E1	E2	E3	E4	E5	E6	E7	E8	E9
MGTB 32	-	-	-	-	-	-	-	-	-	-
MGTB 32 - VK - 42	5.5	M12 5-pole	M12 8-pole	M8 3-pole (with brake)	14 (± 1)	14 (± 0.3)	19.5	9 (± 1) (with brake)	27 (± 0.3) (with brake)	70.4 (± 1) (without brake) ; 106.4 (± 1) (with brake)
MGTB 45	-	-	-	-	-	-	-	-	-	-
MGTB 45 - VK - 42	0	M12 5-pole	M12 8-pole	M8 3-pole (with brake)	14 (± 1)	14 (± 0.3)	19.5	9 (± 1) (with brake)	27 (± 0.3) (with brake)	70.4 (± 1) (without brake) ; 106.4 (± 1) (with brake)
MGTB 45 - VK - 56	9.5	M12 5-pole	M12 8-pole	M8 3-pole (with brake)	14 (± 1)	13.4 (± 0.3) (without brake) ; 52.4 (± 0.3) (with brake)	23	9 (± 1) (with brake)	12 (± 0.3) (with brake)	98 (± 1) (without brake) ; 138 (± 1) (with brake)
MGTB 60	-	-	-	-	-	-	-	-	-	-
MGTB 60 - VK - 56	0	M12 5-pole	M12 8-pole	M8 3-pole (with brake)	14 (± 1)	13.4 (± 0.3) (without brake) ; 52.4 (± 0.3) (with brake)	23	9 (± 1) (with brake)	12 (± 0.3) (with brake)	98 (± 1) (without brake) ; 138 (± 1) (with brake)
MGTB 60 - VK - 86	9.5	Currently not available	Currently not available	Currently not available	Currently not available	Currently not available	Currently not available	Currently not available	Currently not available	Currently not available

Designation	E10
MGTB 32	-
MGTB 32 - VK - 42	42.3
MGTB 45	-
MGTB 45 - VK - 42	42.3
MGTB 45 - VK - 56	56.4
MGTB 60	-
MGTB 60 - VK - 56	56.4
MGTB 60 - VK - 86	Currently not available

Drive Data

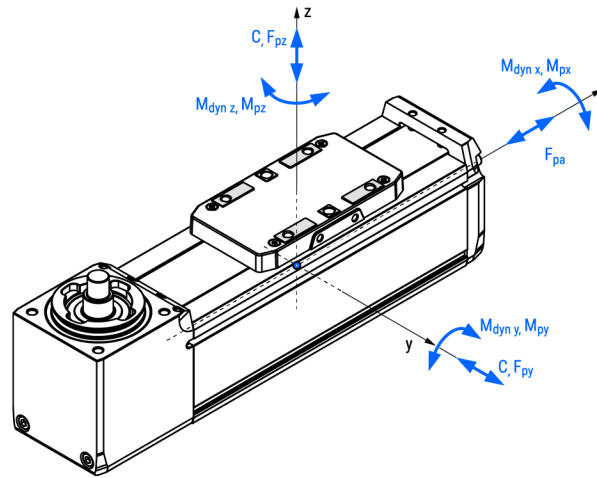

Designation	Description	Pulley Drive Ratio (mm/rev)	Pulley Diameter (mm)	Motor Type	Motor Size (mm)
MGTB 32	Without a motor	66	21.00	-	-
MGTB 32 - VK - 42	With motor size 42 and motor adapter VK	66	21.00	Stepper	42
MGTB 45	Without a motor	63	20.05	-	-
MGTB 45 - VK - 42	With motor size 42 and motor adapter VK	63	20.05	Stepper	42
MGTB 45 - VK - 56	With motor size 56 and motor adapter VK	63	20.05	Stepper	56
MGTB 60	Without a motor	78	24.83	-	-
MGTB 60 - VK - 56	With motor size 56 and motor adapter VK	78	24.83	Stepper	56
MGTB 60 - VK - 86	With motor size 86 and motor adapter VK	78	24.83	Stepper	86

Designation	Max. Permissible Axial Load Fpa (N)	Max. Permissible Payload Horizontal mph (kg)	Max. Permissible Payload Vertical mpv (kg)	Max. Drive Torque Mp (Nm)	No Load Torque Mo (Nm)	Max. Permissible Radial Load on Shaft Fpr (N)
MGTB 32	65	31	5.4	0.68	0.07	50
MGTB 32 - VK - 42	25	0.9	0.9	-	-	-
MGTB 45	85	42	7.1	0.85	0.20	100
MGTB 45 - VK - 42	10	0.9	0.7	-	-	-
MGTB 45 - VK - 56	85	6.2	6.2	-	-	-
MGTB 60	130	65	11	1.61	0.40	200
MGTB 60 - VK - 56	55	3.6	3.6	-	-	-
MGTB 60 - VK - 86	Currently not available	Currently not available	Currently not available	-	-	-

Designation	Max. Travel Speed Vmax (m/s)	Max. Rotational Speed (rev/min)	Max. Acceleration (m/s ²)
MGTB 32	1500	1365	20

Drive Data

Designation	Max. Travel Speed Vmax (m/s)	Max. Rotational Speed (rev/min)	Max. Acceleration (m/s ²)
MGTB 32 - VK - 42	1500	1365	20
MGTB 45	1500	1430	20
MGTB 45 - VK - 42	1344	1280	20
MGTB 45 - VK - 56	1500	1430	20
MGTB 60	1500	1155	20
MGTB 60 - VK - 56	1500	1155	20
MGTB 60 - VK - 86	Currently not available	Currently not available	20

Mass and Mass Moment of Inertia

Designation	Description	Moved Mass (kg)	Mass of Linear Unit (kg)	Mass Moment of Inertia JMGTB (10^{-2} kg cm ²)	Mass of the motor and motor adapter VK (kg)
MGTB 32	Without a motor	0.06	$0.37 + 0.0012 \times \text{Abs. Stroke}$	$9.19 + 0.0024 \times \text{Abs. Stroke} + 110.339 \times \text{mload}$	-
MGTB 32 - VK - 42	With motor size 42 and motor adapter VK	0.06	$0.37 + 0.0012 \times \text{Abs. Stroke}$	$9.19 + 0.0024 \times \text{Abs. Stroke} + 110.339 \times \text{mload}$	0.52 without brake ; 0.65 with brake
MGTB 45	Without a motor	0.15	$0.92 + 0.0023 \times \text{Abs. Stroke}$	$18.80 + 0.0022 \times \text{Abs. Stroke} + 100.536 \times \text{mload}$	-
MGTB 45 - VK - 42	With motor size 42 and motor adapter VK	0.15	$0.92 + 0.0023 \times \text{Abs. Stroke}$	$18.80 + 0.0022 \times \text{Abs. Stroke} + 100.536 \times \text{mload}$	0.57 without brake ; 0.70 with brake
MGTB 45 - VK - 56	With motor size 56 and motor adapter VK	0.15	$0.92 + 0.0023 \times \text{Abs. Stroke}$	$18.80 + 0.0022 \times \text{Abs. Stroke} + 100.536 \times \text{mload}$	1.31 without brake ; 1.50 with brake
MGTB 60	Without a motor	0.45	$2.12 + 0.0041 \times \text{Abs. Stroke}$	$81.72 + 0.0040 \times \text{Abs. Stroke} + 154.110 \times \text{mload}$	-
MGTB 60 - VK - 56	With motor size 56 and motor adapter VK	0.45	$2.12 + 0.0041 \times \text{Abs. Stroke}$	$81.72 + 0.0040 \times \text{Abs. Stroke} + 154.110 \times \text{mload}$	1.50 without brake ; 1.69 with brake
MGTB 60 - VK - 86	With motor size 86 and motor adapter VK	0.45	$2.12 + 0.0041 \times \text{Abs. Stroke}$	$81.72 + 0.0040 \times \text{Abs. Stroke} + 154.110 \times \text{mload}$	Currently not available

Designation	Planar Moment of Inertia I _y (cm ⁴)	Planar Moment of Inertia I _z (cm ⁴)	Holding Torque Motor Brake (Nm)
MGTB 32	4.3	4.6	-
MGTB 32 - VK - 42	4.3	4.6	0.4
MGTB 45	14.3	15.9	-
MGTB 45 - VK - 42	14.3	15.9	0.4
MGTB 45 - VK - 56	14.3	15.9	1.0
MGTB 60	43.8	50.3	-
MGTB 60 - VK - 56	43.8	50.3	1.0
MGTB 60 - VK - 86	43.8	50.3	Currently not available