

MGBS

The MGBS is a ball screw driven mini linear unit where the rotary motion (rotation) of the drive shaft is converted to the linear motion (translation) of the carriage with high mechanical efficiency and low internal friction.

High-performance features such as high speed, good positioning accuracy, and high repeatability are ensured through a precision ball screw drive and a linear guiding system.

A preassembled standard motor (in-line with a motor adapter and a coupling or in-parallel with a motor side drive and a timing belt) together with a standard drive, makes the system plug and drive ready. Compact dimensions and optimally selected motor combinations cover a wide range of applications.

Options, such as different ball screw leads, together with a wide range of accessories and possible multi-axis system combinations make this product highly flexible.

□ = Square cross section

Dimensions in mm.

For other CAD files, please contact Rollco.

Ambient Temperature (°C): 0 °C ~ +50 °C

Ambient Temperature without a Motor (°C): 0 °C ~ +60 °C

Protection Class: IP40

Duty Cycle: 100%

Maintenance: Life-time pre-lubricated

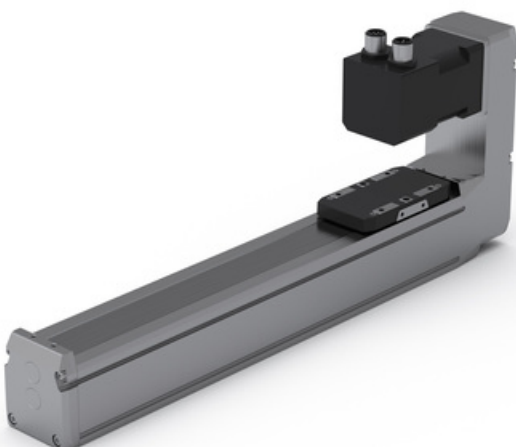

MGBS

MGBS with motor and motor adapter VK

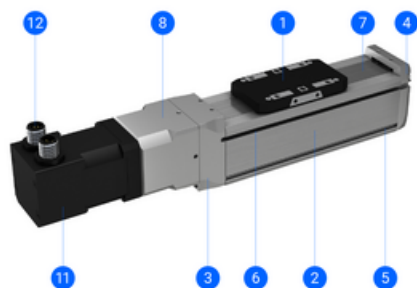

1. Carriage
2. Aluminium profile
3. Drive block
4. End block
5. Mounting slots
6. Slot for the magnetic field sensors
7. Corrosion-resistance protection strip
8. Motor adapter VK with a coupling
11. Preassembled motor (with/without a brake)
12. Standard connectors (motor, encoder and brake - optionally)

MGBS with motor and motor side drive MSD



9. Motor side drive MSD with a timing belt
11. Preassembled motor (with/without a brake)
12. Standard connectors (motor, encoder and brake - optionally)

MGBS without motor

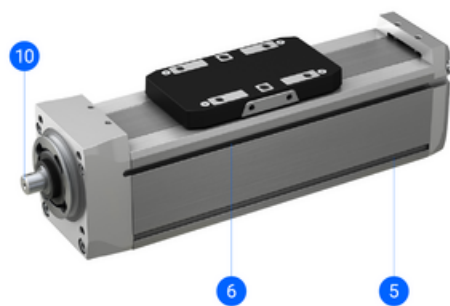

5. Mounting slots
6. Slot for the magnetic field sensors
10. Drive shaft of the precision ball screw drive

General Data

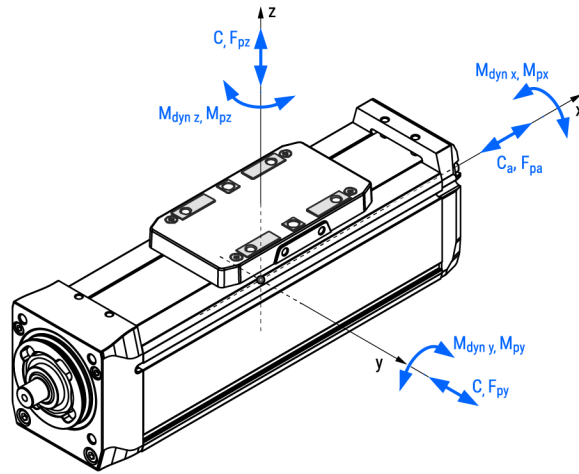

Designation	Description	Ball Screw (d x l)	Axial Dynamic Load Capacity Ca (N)	Dynamic Load Capacity C (N)	Dynamic Moment Mx (Nm)
MGBS 32 - 8x2	Without a motor	8 x 2	2000	1310	4.8
MGBS 32 - VK - 28 - 8x2	With motor size 28 and motor adapter VK	8 x 2	2000	1310	4.8
MGBS 32 - MSD - 28 - 8x2	With motor size 28 and motor side drive MSD	8 x 2	2000	1310	4.8
MGBS 32 - VK - 42 - 8x2	With motor size 42 and motor adapter VK	8 x 2	2000	1310	4.8
MGBS 32 - MSD - 42 - 8x2	With motor size 42 and motor side drive MSD	8 x 2	2000	1310	4.8
MGBS 32 - 8x8	Without a motor	8 x 8	1500	1310	4.8
MGBS 32 - VK - 28 - 8x8	With motor size 28 and motor adapter VK	8 x 8	1500	1310	4.8
MGBS 32 - MSD - 28 - 8x8	With motor size 28 and motor side drive MSD	8 x 8	1500	1310	4.8
MGBS 32 - VK - 42 - 8x8	With motor size 42 and motor adapter VK	8 x 8	1500	1310	4.8
MGBS 32 - MSD - 42 - 8x8	With motor size 42 and motor side drive MSD	8 x 8	1500	1310	4.8
MGBS 45 - 10x3	Without a motor	10 x 3	3500	3240	20.1
MGBS 45 - VK - 42 - 10x3	With motor size 42 and motor adapter VK	10 x 3	3500	3240	20.1
MGBS 45 - MSD - 42 - 10x3	With motor size 42 and motor side drive MSD	10 x 3	3500	3240	20.1
MGBS 45 - VK - 56 - 10x3	With motor size 56 and motor side drive MSD	10 x 3	3500	3240	20.1
MGBS 45 - MSD - 56 - 10x3	With motor size 56 and motor side drive MSD	10 x 3	3500	3240	20.1

General Data

Designation	Description	Ball Screw (d x l)	Axial Dynamic Load Capacity Ca (N)	Dynamic Load Capacity C (N)	Dynamic Moment Mx (Nm)
MGBS 45 - 10x10	Without a motor	10 x 10	3200	3240	20.1
MGBS 45 - VK - 42 - 10x10	With motor size 42 and motor adapter VK	10 x 10	3200	3240	20.1
MGBS 45 - MSD - 42 - 10x10	With motor size 42 and motor side drive MSD	10 x 10	3200	3240	20.1
MGBS 45 - VK - 56 - 10x10	With motor size 56 and motor side drive MSD	10 x 10	3200	3240	20.1
MGBS 45 - MSD - 56 - 10x10	With motor size 56 and motor side drive MSD	10 x 10	3200	3240	20.1
MGBS 60 - 12x5	Without a motor	12 x 5	5000	11190	77.4
MGBS 60 - VK - 56 - 12x5	With motor size 56 and motor side drive MSD	12 x 5	5000	11190	77.4
MGBS 60 - MSD - 56 - 12x5	With motor size 56 and motor side drive MSD	12 x 5	5000	11190	77.4
MGBS 60 - VK - 86 - 12x5	With motor size 86 and motor side drive MSD	12 x 5	5000	11190	77.4
MGBS 60 - MSD - 86 - 12x5	With motor size 86 and motor side drive MSD	12 x 5	5000	11190	77.4
MGBS 60 - 12x10	Without a motor	12 x 10	3800	11190	77.4
MGBS 60 - VK - 56 - 12x10	With motor size 56 and motor side drive MSD	12 x 10	3800	11190	77.4
MGBS 60 - MSD - 56 - 12x10	With motor size 56 and motor side drive MSD	12 x 10	3800	11190	77.4
MGBS 60 - VK - 86 - 12x10	With motor size 86 and motor side drive MSD	12 x 10	3800	11190	77.4
MGBS 60 - MSD - 86 - 12x10	With motor size 86 and motor side drive MSD	12 x 10	3800	11190	77.4

Designation	Dynamic Moment My (Nm)	Dynamic Moment Mz (Nm)	Max. Permissible Loads Forces Fpy (N)	Max. Permissible Loads Forces Fpz (N)	Max. Permissible Loads Moments Mpx (Nm)	Max. Permissible Loads Moments Mpy (Nm)
MGBS 32 - 8x2	4.1	4.1	200	300	2.0	1.8
MGBS 32 - VK - 28 - 8x2	4.1	4.1	200	300	2.0	1.8
MGBS 32 - MSD - 28 - 8x2	4.1	4.1	200	300	2.0	1.8
MGBS 32 - VK - 42 - 8x2	4.1	4.1	200	300	2.0	1.8
MGBS 32 - MSD - 42 - 8x2	4.1	4.1	200	300	2.0	1.8
MGBS 32 - 8x8	4.1	4.1	200	300	2.0	1.8
MGBS 32 - VK - 28 - 8x8	4.1	4.1	200	300	2.0	1.8
MGBS 32 - MSD - 28 - 8x8	4.1	4.1	200	300	2.0	1.8
MGBS 32 - VK - 42 - 8x8	4.1	4.1	200	300	2.0	1.8

General Data

Designation	Dynamic Moment My (Nm)	Dynamic Moment Mz (Nm)	Max. Permissible Loads Forces Fpy (N)	Max. Permissible Loads Forces Fpz (N)	Max. Permissible Loads Moments Mpx (Nm)	Max. Permissible Loads Moments Mpy (Nm)
MGBS 32 - MSD - 42 - 8×8	4.1	4.1	200	300	2.0	1.8
MGBS 45 - 10×3	17.4	17.4	400	700	7.4	6.3
MGBS 45 - VK - 42 - 10×3	17.4	17.4	400	700	7.4	6.3
MGBS 45 - MSD - 42 - 10×3	17.4	17.4	400	700	7.4	6.3
MGBS 45 - VK - 56 - 10×3	17.4	17.4	400	700	7.4	6.3
MGBS 45 - MSD - 56 - 10×3	17.4	17.4	400	700	7.4	6.3
MGBS 45 - 10×10	17.4	17.4	400	700	7.4	6.3
MGBS 45 - VK - 42 - 10×10	17.4	17.4	400	700	7.4	6.3
MGBS 45 - MSD - 42 - 10×10	17.4	17.4	400	700	7.4	6.3
MGBS 45 - VK - 56 - 10×10	17.4	17.4	400	700	7.4	6.3
MGBS 45 - MSD - 56 - 10×10	17.4	17.4	400	700	7.4	6.3
MGBS 60 - 12×5	79.8	79.8	850	2000	29.2	30.8
MGBS 60 - VK - 56 - 12×5	79.8	79.8	850	2000	29.2	30.8
MGBS 60 - MSD - 56 - 12×5	79.8	79.8	850	2000	29.2	30.8
MGBS 60 - VK - 86 - 12×5	79.8	79.8	850	2000	29.2	30.8
MGBS 60 - MSD - 86 - 12×5	79.8	79.8	850	2000	29.2	30.8
MGBS 60 - 12×10	79.8	79.8	850	2000	29.2	30.8
MGBS 60 - VK - 56 - 12×10	79.8	79.8	850	2000	29.2	30.8
MGBS 60 - MSD - 56 - 12×10	79.8	79.8	850	2000	29.2	30.8
MGBS 60 - VK - 86 - 12×10	79.8	79.8	850	2000	29.2	30.8
MGBS 60 - MSD - 86 - 12×10	79.8	79.8	850	2000	29.2	30.8

Designation	Max. Permissible Loads Moments Mpz (Nm)	Axial Backlash (mm)	Max. Repeatability (mm)	Absolute Stroke
MGBS 32 - 8×2	1.3	≤ 0.06	± 0.015	50, 100, 150, 200, 250, 300, 400, 500, 600, 700, 800
MGBS 32 - VK - 28 - 8×2	1.3	≤ 0.06	± 0.015	50, 100, 150, 200, 250, 300, 400, 500, 600, 700, 800
MGBS 32 - MSD - 28 - 8×2	1.3	≤ 0.06	± 0.015	50, 100, 150, 200, 250, 300, 400, 500, 600, 700, 800
MGBS 32 - VK - 42 - 8×2	1.3	≤ 0.06	± 0.015	50, 100, 150, 200, 250, 300, 400, 500, 600, 700, 800
MGBS 32 - MSD - 42 - 8×2	1.3	≤ 0.06	± 0.015	50, 100, 150, 200, 250, 300, 400, 500, 600, 700, 800
MGBS 32 - 8×8	1.3	≤ 0.06	± 0.015	50, 100, 150, 200, 250, 300, 400, 500, 600, 700, 800
MGBS 32 - VK - 28 - 8×8	1.3	≤ 0.06	± 0.015	50, 100, 150, 200, 250, 300, 400, 500, 600, 700, 800

General Data

Designation	Max. Permissible Loads Moments Mpz (Nm)	Axial Backlash (mm)	Max. Repeatability (mm)	Absolute Stroke
MGBS 32 - MSD - 28 - 8×8	1.3	≤ 0.06	± 0.015	50, 100, 150, 200, 250, 300, 400, 500, 600, 700, 800
MGBS 32 - VK - 42 - 8×8	1.3	≤ 0.06	± 0.015	50, 100, 150, 200, 250, 300, 400, 500, 600, 700, 800
MGBS 32 - MSD - 42 - 8×8	1.3	≤ 0.06	± 0.015	50, 100, 150, 200, 250, 300, 400, 500, 600, 700, 800
MGBS 45 - 10×3	4.7	≤ 0.06	± 0.015	50, 100, 150, 200, 250, 300, 400, 500, 600, 700, 800
MGBS 45 - VK - 42 - 10×3	4.7	≤ 0.06	± 0.015	50, 100, 150, 200, 250, 300, 400, 500, 600, 700, 800
MGBS 45 - MSD - 42 - 10×3	4.7	≤ 0.06	± 0.015	50, 100, 150, 200, 250, 300, 400, 500, 600, 700, 800
MGBS 45 - VK - 56 - 10×3	4.7	≤ 0.06	± 0.015	50, 100, 150, 200, 250, 300, 400, 500, 600, 700, 800
MGBS 45 - MSD - 56 - 10×3	4.7	≤ 0.06	± 0.015	50, 100, 150, 200, 250, 300, 400, 500, 600, 700, 800
MGBS 45 - 10×10	4.7	≤ 0.06	± 0.015	50, 100, 150, 200, 250, 300, 400, 500, 600, 700, 800
MGBS 45 - VK - 42 - 10×10	4.7	≤ 0.06	± 0.015	50, 100, 150, 200, 250, 300, 400, 500, 600, 700, 800
MGBS 45 - MSD - 42 - 10×10	4.7	≤ 0.06	± 0.015	50, 100, 150, 200, 250, 300, 400, 500, 600, 700, 800
MGBS 45 - VK - 56 - 10×10	4.7	≤ 0.06	± 0.015	50, 100, 150, 200, 250, 300, 400, 500, 600, 700, 800
MGBS 45 - MSD - 56 - 10×10	4.7	≤ 0.06	± 0.015	50, 100, 150, 200, 250, 300, 400, 500, 600, 700, 800
MGBS 60 - 12×5	31.8	≤ 0.06	± 0.010	50, 100, 150, 200, 250, 300, 400, 500, 600, 700, 800, 900, 1000
MGBS 60 - VK - 56 - 12×5	31.8	≤ 0.06	± 0.010	50, 100, 150, 200, 250, 300, 400, 500, 600, 700, 800, 900, 1000
MGBS 60 - MSD - 56 - 12×5	31.8	≤ 0.06	± 0.010	50, 100, 150, 200, 250, 300, 400, 500, 600, 700, 800, 900, 1000
MGBS 60 - VK - 86 - 12×5	31.8	≤ 0.06	± 0.010	50, 100, 150, 200, 250, 300, 400, 500, 600, 700, 800, 900, 1000

General Data

Designation	Max. Permissible Loads Moments Mpz (Nm)	Axial Backlash (mm)	Max. Repeatability (mm)	Absolute Stroke
MGBS 60 - MSD - 86 - 12×5	31.8	≤ 0.06	± 0.010	50, 100, 150, 200, 250, 300, 400, 500, 600, 700, 800, 900, 1000
MGBS 60 - 12×10	31.8	≤ 0.06	± 0.010	50, 100, 150, 200, 250, 300, 400, 500, 600, 700, 800, 900, 1000
MGBS 60 - VK - 56 - 12×10	31.8	≤ 0.06	± 0.010	50, 100, 150, 200, 250, 300, 400, 500, 600, 700, 800, 900, 1000
MGBS 60 - MSD - 56 - 12×10	31.8	≤ 0.06	± 0.010	50, 100, 150, 200, 250, 300, 400, 500, 600, 700, 800, 900, 1000
MGBS 60 - VK - 86 - 12×10	31.8	≤ 0.06	± 0.010	50, 100, 150, 200, 250, 300, 400, 500, 600, 700, 800, 900, 1000
MGBS 60 - MSD - 86 - 12×10	31.8	≤ 0.06	± 0.010	50, 100, 150, 200, 250, 300, 400, 500, 600, 700, 800, 900, 1000

Dimensions

MGBS without motor

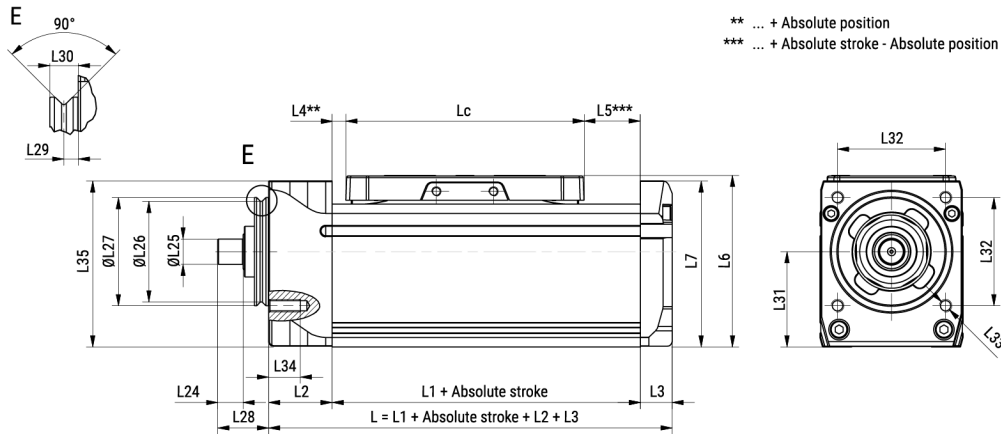

MGBS with motor and motor side drive MSD

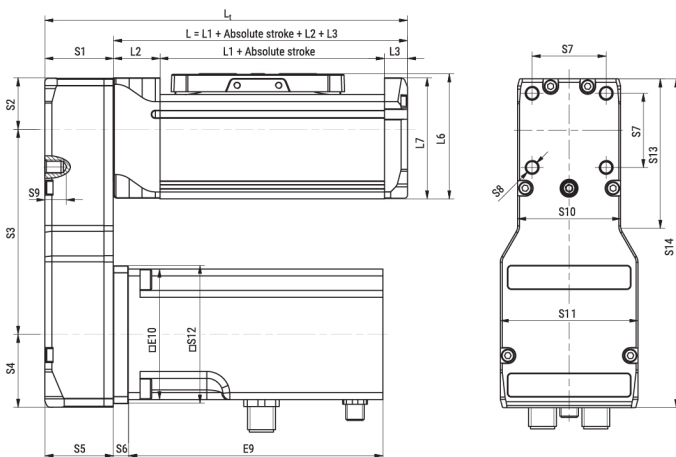

MGBS with motor and motor adapter VK

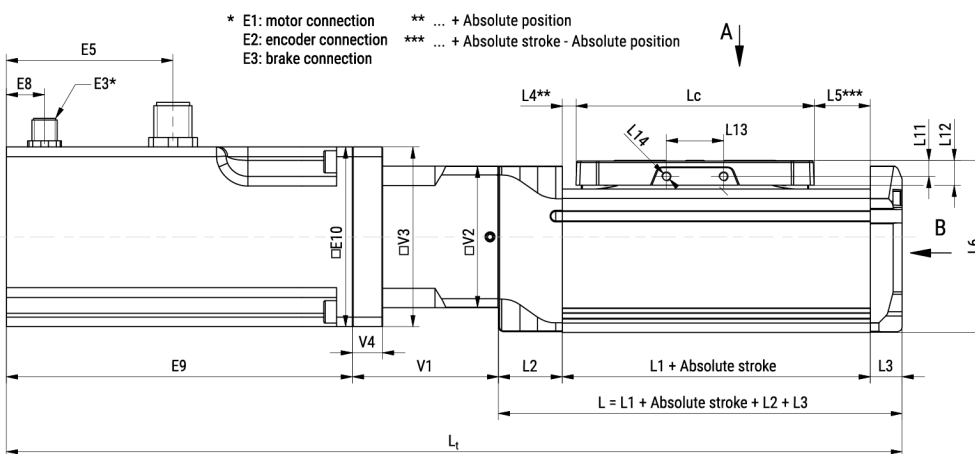

Dimensions

MGBS with motor and motor adapter VK

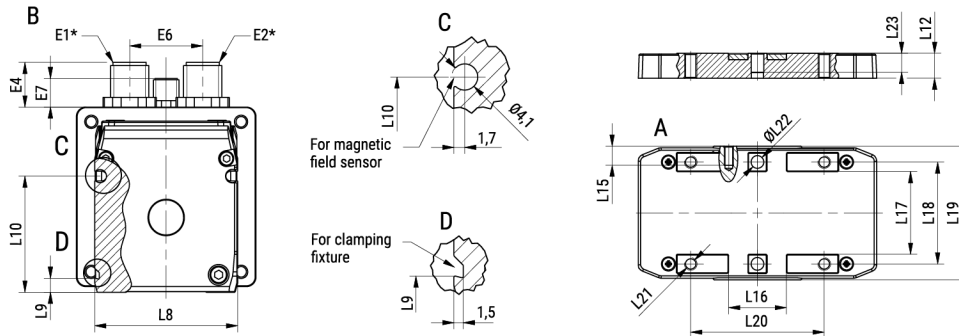

Absolute stroke of the MGBS definition

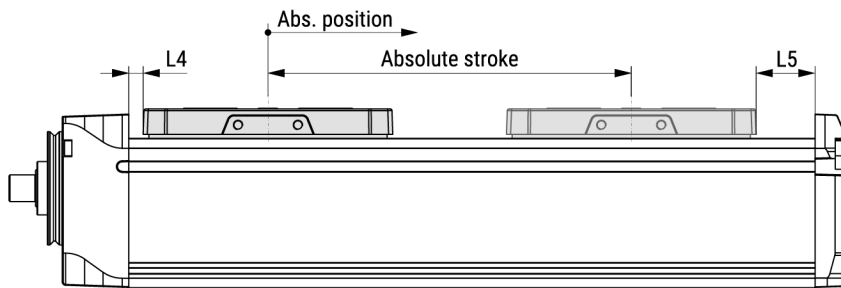

Designation	Lc	L1	L2	L3	L4	L5	L6	L7	L8
MGBS 32 - 8×2	65	81.5	16	8	2.5	14	38.5	35.75	32
MGBS 32 - VK - 28 - 8×2	65	81.5	16	8	2.5	14	38.5	35.75	32
MGBS 32 - MSD - 28 - 8×2	65	81.5	16	8	2.5	14	38.5	35.75	32
MGBS 32 - VK - 42 - 8×2	65	81.5	16	8	2.5	14	38.5	35.75	32
MGBS 32 - MSD - 42 - 8×2	65	81.5	16	8	2.5	14	38.5	35.75	32
MGBS 32 - 8×8	65	81.5	16	8	2.5	14	38.5	35.75	32
MGBS 32 - VK - 28 - 8×8	65	81.5	16	8	2.5	14	38.5	35.75	32
MGBS 32 - MSD - 28 - 8×8	65	81.5	16	8	2.5	14	38.5	35.75	32
MGBS 32 - VK - 42 - 8×8	65	81.5	16	8	2.5	14	38.5	35.75	32
MGBS 32 - MSD - 42 - 8×8	65	81.5	16	8	2.5	14	38.5	35.75	32
MGBS 45 - 10×3	75	97	20	10	4.3	17.7	54	52.25	45
MGBS 45 - VK - 42 - 10×3	75	97	20	10	4.3	17.7	54	52.25	45
MGBS 45 - MSD - 42 - 10×3	75	97	20	10	4.3	17.7	54	52.25	45
MGBS 45 - VK - 56 - 10×3	75	97	20	10	4.3	17.7	54	52.25	45
MGBS 45 - MSD - 56 - 10×3	75	97	20	10	4.3	17.7	54	52.25	45
MGBS 45 - 10×10	75	97	20	10	4.3	17.7	54	52.25	45
MGBS 45 - VK - 42 - 10×10	75	97	20	10	4.3	17.7	54	52.25	45
MGBS 45 - MSD - 42 - 10×10	75	97	20	10	4.3	17.7	54	52.25	45
MGBS 45 - VK - 56 - 10×10	75	97	20	10	4.3	17.7	54	52.25	45
MGBS 45 - MSD - 56 - 10×10	75	97	20	10	4.3	17.7	54	52.25	45

Dimensions

Designation	Lc	L1	L2	L3	L4	L5	L6	L7	L8
MGBS 60 - 12x5	90	133	24	12	3.2	39.8	72	68.75	60
MGBS 60 - VK - 56 - 12x5	90	133	24	12	3.2	39.8	72	68.75	60
MGBS 60 - MSD - 56 - 12x5	90	133	24	12	3.2	39.8	72	68.75	60
MGBS 60 - VK - 86 - 12x5	90	133	24	12	3.2	39.8	72	68.75	60
MGBS 60 - MSD - 86 - 12x5	90	133	24	12	3.2	39.8	72	68.75	60
MGBS 60 - 12x10	90	133	24	12	3.2	39.8	72	68.75	60
MGBS 60 - VK - 56 - 12x10	90	133	24	12	3.2	39.8	72	68.75	60
MGBS 60 - MSD - 56 - 12x10	90	133	24	12	3.2	39.8	72	68.75	60
MGBS 60 - VK - 86 - 12x10	90	133	24	12	3.2	39.8	72	68.75	60
MGBS 60 - MSD - 86 - 12x10	90	133	24	12	3.2	39.8	72	68.75	60

Designation	L9	L10	L11	L12	L13	L14	L15	L16	L17	L18
MGBS 32 - 8×2	4.4	23.7	4	5.9	18	M2	4	14.6	18.4	22.5
MGBS 32 - VK - 28 - 8×2	4.4	23.7	4	5.9	18	M2	4	14.6	18.4	22.5
MGBS 32 - MSD - 28 - 8×2	4.4	23.7	4	5.9	18	M2	4	14.6	18.4	22.5
MGBS 32 - VK - 42 - 8×2	4.4	23.7	4	5.9	18	M2	4	14.6	18.4	22.5
MGBS 32 - MSD - 42 - 8×2	4.4	23.7	4	5.9	18	M2	4	14.6	18.4	22.5
MGBS 32 - 8×8	4.4	23.7	4	5.9	18	M2	4	14.6	18.4	22.5
MGBS 32 - VK - 28 - 8×8	4.4	23.7	4	5.9	18	M2	4	14.6	18.4	22.5
MGBS 32 - MSD - 28 - 8×8	4.4	23.7	4	5.9	18	M2	4	14.6	18.4	22.5
MGBS 32 - VK - 42 - 8×8	4.4	23.7	4	5.9	18	M2	4	14.6	18.4	22.5
MGBS 32 - MSD - 42 - 8×8	4.4	23.7	4	5.9	18	M2	4	14.6	18.4	22.5
MGBS 45 - 10×3	4.4	36.5	5	7.8	18	M3	6	18.6	26.4	32
MGBS 45 - VK - 42 - 10×3	4.4	36.5	5	7.8	18	M3	6	18.6	26.4	32
MGBS 45 - MSD - 42 - 10×3	4.4	36.5	5	7.8	18	M3	6	18.6	26.4	32
MGBS 45 - VK - 56 - 10×3	4.4	36.5	5	7.8	18	M3	6	18.6	26.4	32
MGBS 45 - MSD - 56 - 10×3	4.4	36.5	5	7.8	18	M3	6	18.6	26.4	32
MGBS 45 - 10×10	4.4	36.5	5	7.8	18	M3	6	18.6	26.4	32
MGBS 45 - VK - 42 - 10×10	4.4	36.5	5	7.8	18	M3	6	18.6	26.4	32
MGBS 45 - MSD - 42 - 10×10	4.4	36.5	5	7.8	18	M3	6	18.6	26.4	32
MGBS 45 - VK - 56 - 10×10	4.4	36.5	5	7.8	18	M3	6	18.6	26.4	32
MGBS 45 - MSD - 56 - 10×10	4.4	36.5	5	7.8	18	M3	6	18.6	26.4	32
MGBS 60 - 12×5	4.4	45	6	11	30	M4	6	25.4	38.4	45
MGBS 60 - VK - 56 - 12×5	4.4	45	6	11	30	M4	6	25.4	38.4	45
MGBS 60 - MSD - 56 - 12×5	4.4	45	6	11	30	M4	6	25.4	38.4	45
MGBS 60 - VK - 86 - 12×5	4.4	45	6	11	30	M4	6	25.4	38.4	45
MGBS 60 - MSD - 86 - 12×5	4.4	45	6	11	30	M4	6	25.4	38.4	45
MGBS 60 - 12×10	4.4	45	6	11	30	M4	6	25.4	38.4	45
MGBS 60 - VK - 56 - 12×10	4.4	45	6	11	30	M4	6	25.4	38.4	45
MGBS 60 - MSD - 56 - 12×10	4.4	45	6	11	30	M4	6	25.4	38.4	45
MGBS 60 - VK - 86 - 12×10	4.4	45	6	11	30	M4	6	25.4	38.4	45
MGBS 60 - MSD - 86 - 12×10	4.4	45	6	11	30	M4	6	25.4	38.4	45

Dimensions

Designation	L19	L20	L21	L22	L23	L24	L25	L26	L27	L28
MGBS 32 - 8×2	30	35	M3	2 (H7)	5	7	5 (h7)	22.6	25 (h7)	14
MGBS 32 - VK - 28 - 8×2	30	35	M3	2 (H7)	5	7	5 (h7)	22.6	25	14
MGBS 32 - MSD - 28 - 8×2	30	35	M3	2 (H7)	5	7	5 (h7)	22.6	25	14
MGBS 32 - VK - 42 - 8×2	30	35	M3	2 (H7)	5	7	5 (h7)	22.6	25	14
MGBS 32 - MSD - 42 - 8×2	30	35	M3	2 (H7)	5	7	5 (h7)	22.6	25	14
MGBS 32 - 8×8	30	35	M3	2 (H7)	5	7	5 (h7)	22.6	25 (h7)	14
MGBS 32 - VK - 28 - 8×8	30	35	M3	2 (H7)	5	7	5 (h7)	22.6	25	14
MGBS 32 - MSD - 28 - 8×8	30	35	M3	2 (H7)	5	7	5 (h7)	22.6	25	14
MGBS 32 - VK - 42 - 8×8	30	35	M3	2 (H7)	5	7	5 (h7)	22.6	25	14
MGBS 32 - MSD - 42 - 8×8	30	35	M3	2 (H7)	5	7	5 (h7)	22.6	25	14
MGBS 45 - 10×3	42	42	M4	4 (H7)	6	8	8 (h7)	31.6	34	16
MGBS 45 - VK - 42 - 10×3	42	42	M4	4 (H7)	6	8	8 (h7)	31.6	34	16
MGBS 45 - MSD - 42 - 10×3	42	42	M4	4 (H7)	6	8	8 (h7)	31.6	34	16
MGBS 45 - VK - 56 - 10×3	42	42	M4	4 (H7)	6	8	8 (h7)	31.6	34	16
MGBS 45 - MSD - 56 - 10×3	42	42	M4	4 (H7)	6	8	8 (h7)	31.6	34	16
MGBS 45 - 10×10	42	42	M4	4 (H7)	6	8	8 (h7)	31.6	34	16
MGBS 45 - VK - 42 - 10×10	42	42	M4	4 (H7)	6	8	8 (h7)	31.6	34	16
MGBS 45 - MSD - 42 - 10×10	42	42	M4	4 (H7)	6	8	8 (h7)	31.6	34	16
MGBS 45 - VK - 56 - 10×10	42	42	M4	4 (H7)	6	8	8 (h7)	31.6	34	16
MGBS 45 - MSD - 56 - 10×10	42	42	M4	4 (H7)	6	8	8 (h7)	31.6	34	16
MGBS 60 - 12×5	57	55	M5	5 (H7)	8	10	10 (h7)	39.6	42	20
MGBS 60 - VK - 56 - 12×5	57	55	M5	5 (H7)	8	10	10 (h7)	39.6	42	20
MGBS 60 - MSD - 56 - 12×5	57	55	M5	5 (H7)	8	10	10 (h7)	39.6	42	20
MGBS 60 - VK - 86 - 12×5	57	55	M5	5 (H7)	8	10	10 (h7)	39.6	42	20
MGBS 60 - MSD - 86 - 12×5	57	55	M5	5 (H7)	8	10	10 (h7)	39.6	42	20
MGBS 60 - 12×10	57	55	M5	5 (H7)	8	10	10 (h7)	39.6	42	20
MGBS 60 - VK - 56 - 12×10	57	55	M5	5 (H7)	8	10	10 (h7)	39.6	42	20
MGBS 60 - MSD - 56 - 12×10	57	55	M5	5 (H7)	8	10	10 (h7)	39.6	42	20
MGBS 60 - VK - 86 - 12×10	57	55	M5	5 (H7)	8	10	10 (h7)	39.6	42	20
MGBS 60 - MSD - 86 - 12×10	57	55	M5	5 (H7)	8	10	10 (h7)	39.6	42	20

Designation	L29	L30	L31	L32	L33	L34	L35	V1	V2	V3
MGBS 32 - 8x2	2.3	4.5	20	24.5	M3	6	35.75	-	-	-
MGBS 32 - VK - 28 - 8x2	2.3	4.5	20	24.5	M3	6	35.75	36	31.5	31.5
MGBS 32 - MSD - 28 - 8x2	2.3	4.5	20	24.5	M3	6	35.75	-	-	-
MGBS 32 - VK - 42 - 8x2	2.3	4.5	20	24.5	M3	6	35.75	40	31.5	42
MGBS 32 - MSD - 42 - 8x2	2.3	4.5	20	24.5	M3	6	35.75	-	-	-
MGBS 32 - 8x8	2.3	4.5	20	24.5	M3	6	35.75	-	-	-
MGBS 32 - VK - 28 - 8x8	2.3	4.5	20	24.5	M3	6	35.75	36	31.5	31.5
MGBS 32 - MSD - 28 - 8x8	2.3	4.5	20	24.5	M3	6	35.75	-	-	-
MGBS 32 - VK - 42 - 8x8	2.3	4.5	20	24.5	M3	6	35.75	40	31.5	42
MGBS 32 - MSD - 42 - 8x8	2.3	4.5	20	24.5	M3	6	35.75	-	-	-
MGBS 45 - 10x3	2.3	4.5	30	34	M4	10	52.25	-	-	-

Dimensions

Designation	L29	L30	L31	L32	L33	L34	L35	V1	V2	V3
MGBS 45 - VK - 42 - 10×3	2.3	4.5	30	34	M4	10	52.25	42	44.5	44.5
MGBS 45 - MSD - 42 - 10×3	2.3	4.5	30	34	M4	10	52.25	-	-	-
MGBS 45 - VK - 56 - 10×3	2.3	4.5	30	34	M4	10	52.25	46	44.5	56.4
MGBS 45 - MSD - 56 - 10×3	2.3	4.5	30	34	M4	10	52.25	-	-	-
MGBS 45 - 10×10	2.3	4.5	30	34	M4	10	52.25	-	-	-
MGBS 45 - VK - 42 - 10×10	2.3	4.5	30	34	M4	10	52.25	42	44.5	44.5
MGBS 45 - MSD - 42 - 10×10	2.3	4.5	30	34	M4	10	52.25	-	-	-
MGBS 45 - VK - 56 - 10×10	2.3	4.5	30	34	M4	10	52.25	46	44.5	56.4
MGBS 45 - MSD - 56 - 10×10	2.3	4.5	30	34	M4	10	52.25	-	-	-
MGBS 60 - 12×5	2.3	4.5	39	48	M5	10	68.75	-	-	-
MGBS 60 - VK - 56 - 12×5	2.3	4.5	39	48	M5	10	68.75	52.5	59.5	59.5
MGBS 60 - MSD - 56 - 12×5	2.3	4.5	39	48	M5	10	68.75	-	-	-
MGBS 60 - VK - 86 - 12×5	2.3	4.5	39	48	M5	10	68.75	69	59.5	86
MGBS 60 - MSD - 86 - 12×5	2.3	4.5	39	48	M5	10	68.75	-	-	-
MGBS 60 - 12×10	2.3	4.5	39	48	M5	10	68.75	-	-	-
MGBS 60 - VK - 56 - 12×10	2.3	4.5	39	48	M5	10	68.75	52.5	59.5	59.5
MGBS 60 - MSD - 56 - 12×10	2.3	4.5	39	48	M5	10	68.75	-	-	-
MGBS 60 - VK - 86 - 12×10	2.3	4.5	39	48	M5	10	68.75	69	59.5	86
MGBS 60 - MSD - 86 - 12×10	2.3	4.5	39	48	M5	10	68.75	-	-	-

Designation	V4	S1	S2	S3	S4	S5	S6	S7	S8	S9
MGBS 32 - 8×2	-	-	-	-	-	-	-	-	-	-
MGBS 32 - VK - 28 - 8×2	0	-	-	-	-	-	-	-	-	-
MGBS 32 - MSD - 28 - 8×2	-	22	15.75	52.5 (± 0.5)	17.25	22	4	22	M5	6
MGBS 32 - VK - 42 - 8×2	5.5	-	-	-	-	-	-	-	-	-
MGBS 32 - MSD - 42 - 8×2	-	22	15.75	70.5 (± 0.5)	23.75	22	4.5	22	M5	6.5
MGBS 32 - 8×8	-	-	-	-	-	-	-	-	-	-
MGBS 32 - VK - 28 - 8×8	0	-	-	-	-	-	-	-	-	-
MGBS 32 - MSD - 28 - 8×8	-	22	15.75	52.5 (± 0.5)	17.25	22	4	22	M5	6
MGBS 32 - VK - 42 - 8×8	5.5	-	-	-	-	-	-	-	-	-
MGBS 32 - MSD - 42 - 8×8	-	22	15.75	70.5 (± 0.5)	23.75	22	4.5	22	M5	6.5
MGBS 45 - 10×3	-	-	-	-	-	-	-	-	-	-
MGBS 45 - VK - 42 - 10×3	0	-	-	-	-	-	-	-	-	-
MGBS 45 - MSD - 42 - 10×3	-	27.5	22.25	81 (± 0.5)	23.75	27.5	4.5	32	M6	8.5
MGBS 45 - VK - 56 - 10×3	9.5	-	-	-	-	-	-	-	-	-
MGBS 45 - MSD - 56 - 10×3	-	27.5	22.25	88.5 (± 0.5)	31.25	27.5	6.5	32	M6	8.5
MGBS 45 - 10×10	-	-	-	-	-	-	-	-	-	-
MGBS 45 - VK - 42 - 10×10	0	-	-	-	-	-	-	-	-	-
MGBS 45 - MSD - 42 - 10×10	-	27.5	22.25	81 (± 0.5)	23.75	27.5	4.5	32	M6	8.5

Dimensions

Designation	V4	S1	S2	S3	S4	S5	S6	S7	S8	S9
MGBS 45 - VK - 56 - 10×10	9.5	-	-	-	-	-	-	-	-	-
MGBS 45 - MSD - 56 - 10×10	-	27.5	22.25	88.5 (± 0.5)	31.25	27.5	6.5	32	M6	8.5
MGBS 60 - 12×5	-	-	-	-	-	-	-	-	-	-
MGBS 60 - VK - 56 - 12×5	0	-	-	-	-	-	-	-	-	-
MGBS 60 - MSD - 56 - 12×5	-	33	29.75	96 (± 0.5)	31.25	33	6.5	38	M6	8
MGBS 60 - VK - 86 - 12×5	9.5	-	-	-	-	-	-	-	-	-
MGBS 60 - MSD - 86 - 12×5	-	33	29.75	121.5 (± 0.5)	44.25	33	8.5	38	M6	8
MGBS 60 - 12×10	-	-	-	-	-	-	-	-	-	-
MGBS 60 - VK - 56 - 12×10	0	-	-	-	-	-	-	-	-	-
MGBS 60 - MSD - 56 - 12×10	-	33	29.75	96 (± 0.5)	31.25	33	6.5	38	M6	8
MGBS 60 - VK - 86 - 12×10	9.5	-	-	-	-	-	-	-	-	-
MGBS 60 - MSD - 86 - 12×10	-	33	29.75	121.5 (± 0.5)	44.25	33	8.5	38	M6	8

Designation	S10	S11	S12	S13	S14	E1	E2	E3	E4	E5
MGBS 32 - 8×2	-	-	-	-	-	-	-	-	-	-
MGBS 32 - VK - 28 - 8×2	-	-	-	-	-	Currently not available	Currently not available	Currently not available	Currently not available	Currently not available
MGBS 32 - MSD - 28 - 8×2	31.5	31.5	44.5	0	85.5	Currently not available	Currently not available	Currently not available	Currently not available	Currently not available
MGBS 32 - VK - 42 - 8×2	-	-	-	-	-	M12 5-pole	M12 8-pole	M8 3-pole (with brake)	14 (± 1)	14 (± 0.3)
MGBS 32 - MSD - 42 - 8×2	31.5	44.5	44.5	48	110	M12 5-pole	M12 8-pole	M8 3-pole (with brake)	14 (± 1)	14 (± 0.3)
MGBS 32 - 8×8	-	-	-	-	-	-	-	-	-	-
MGBS 32 - VK - 28 - 8×8	-	-	-	-	-	Currently not available	Currently not available	Currently not available	Currently not available	Currently not available
MGBS 32 - MSD - 28 - 8×8	31.5	31.5	44.5	0	85.5	Currently not available	Currently not available	Currently not available	Currently not available	Currently not available
MGBS 32 - VK - 42 - 8×8	-	-	-	-	-	M12 5-pole	M12 8-pole	M8 3-pole (with brake)	14 (± 1)	14 (± 0.3)
MGBS 32 - MSD - 42 - 8×8	31.5	44.5	44.5	48	110	M12 5-pole	M12 8-pole	M8 3-pole (with brake)	14 (± 1)	14 (± 0.3)
MGBS 45 - 10×3	-	-	-	-	-	-	-	-	-	-
MGBS 45 - VK - 42 - 10×3	-	-	-	-	-	M12 5-pole	M12 8-pole	M8 3-pole (with brake)	14 (± 1)	14 (± 0.3)
MGBS 45 - MSD - 42 - 10×3	44.5	44.5	59.5	0	127	M12 5-pole	M12 8-pole	M8 3-pole (with brake)	14 (± 1)	14 (± 0.3)

Dimensions

Designation	S10	S11	S12	S13	S14	E1	E2	E3	E4	E5
MGBS 45 - VK - 56 - 10×3	-	-	-	-	-	M12 5-pole	M12 8-pole	M8 3-pole (with brake)	14 (± 1)	13.4 (± 0.3) (without brake) ; 52.4 (± 0.3) (with brake)
MGBS 45 - MSD - 56 - 10×3	44.5	59.5	59.5	63.5	142	M12 5-pole	M12 8-pole	M8 3-pole (with brake)	14 (± 1)	13.4 (± 0.3) (without brake) ; 52.4 (± 0.3) (with brake)
MGBS 45 - 10×10	-	-	-	-	-	-	-	-	-	-
MGBS 45 - VK - 42 - 10×10	-	-	-	-	-	M12 5-pole	M12 8-pole	M8 3-pole (with brake)	14 (± 1)	14 (± 0.3)
MGBS 45 - MSD - 42 - 10×10	44.5	44.5	59.5	0	127	M12 5-pole	M12 8-pole	M8 3-pole (with brake)	14 (± 1)	14 (± 0.3)
MGBS 45 - VK - 56 - 10×10	-	-	-	-	-	M12 5-pole	M12 8-pole	M8 3-pole (with brake)	14 (± 1)	13.4 (± 0.3) (without brake) ; 52.4 (± 0.3) (with brake)
MGBS 45 - MSD - 56 - 10×10	44.5	59.5	59.5	63.5	142	M12 5-pole	M12 8-pole	M8 3-pole (with brake)	14 (± 1)	13.4 (± 0.3) (without brake) ; 52.4 (± 0.3) (with brake)
MGBS 60 - 12×5	-	-	-	-	-	-	-	-	-	-
MGBS 60 - VK - 56 - 12×5	-	-	-	-	-	M12 5-pole	M12 8-pole	M8 3-pole (with brake)	14 (± 1)	13.4 (± 0.3) (without brake) ; 52.4 (± 0.3) (with brake)
MGBS 60 - MSD - 56 - 12×5	59.5	59.5	85.5	0	157	M12 5-pole	M12 8-pole	M8 3-pole (with brake)	14 (± 1)	13.4 (± 0.3) (without brake) ; 52.4 (± 0.3) (with brake)
MGBS 60 - VK - 86 - 12×5	-	-	-	-	-	Currently not available	Currently not available	Currently not available	Currently not available	Currently not available
MGBS 60 - MSD - 86 - 12×5	59.5	85.5	86.5	81.5	195.5	Currently not available	Currently not available	Currently not available	Currently not available	Currently not available
MGBS 60 - 12×10	-	-	-	-	-	-	-	-	-	-
MGBS 60 - VK - 56 - 12×10	-	-	-	-	-	M12 5-pole	M12 8-pole	M8 3-pole (with brake)	14 (± 1)	13.4 (± 0.3) (without brake) ; 52.4 (± 0.3) (with brake)

Dimensions

Designation	S10	S11	S12	S13	S14	E1	E2	E3	E4	E5
MGBS 60 - MSD - 56 - 12×10	59.5	59.5	85.5	0	157	M12 5-pole	M12 8-pole	M8 3-pole (with brake)	14 (± 1)	13.4 (± 0.3) (without brake) ; 52.4 (± 0.3) (with brake)
MGBS 60 - VK - 86 - 12×10	-	-	-	-	-	Currently not available	Currently not available	Currently not available	Currently not available	Currently not available
MGBS 60 - MSD - 86 - 12×10	59.5	85.5	86.5	81.5	195.5	Currently not available	Currently not available	Currently not available	Currently not available	Currently not available

Designation	E6	E7	E8	E9	E10
MGBS 32 - 8×2	-	-	-	-	-
MGBS 32 - VK - 28 - 8×2	Currently not available	Currently not available	Currently not available	Currently not available	Currently not available
MGBS 32 - MSD - 28 - 8×2	Currently not available	Currently not available	Currently not available	Currently not available	Currently not available
MGBS 32 - VK - 42 - 8×2	19.5	9 (± 1) (with brake)	27 (± 0.3) (with brake)	70.4 (± 1) (without brake) ; 106.4 (± 1) (with brake)	42.3
MGBS 32 - MSD - 42 - 8×2	19.5	9 (± 1) (with brake)	27 (± 0.3) (with brake)	70.4 (± 1) (without brake) ; 106.4 (± 1) (with brake)	42.3
MGBS 32 - 8×8	-	-	-	-	-
MGBS 32 - VK - 28 - 8×8	Currently not available	Currently not available	Currently not available	Currently not available	Currently not available
MGBS 32 - MSD - 28 - 8×8	Currently not available	Currently not available	Currently not available	Currently not available	Currently not available
MGBS 32 - VK - 42 - 8×8	19.5	9 (± 1) (with brake)	27 (± 0.3) (with brake)	70.4 (± 1) (without brake) ; 106.4 (± 1) (with brake)	42.3
MGBS 32 - MSD - 42 - 8×8	19.5	9 (± 1) (with brake)	27 (± 0.3) (with brake)	70.4 (± 1) (without brake) ; 106.4 (± 1) (with brake)	42.3
MGBS 45 - 10×3	-	-	-	-	-
MGBS 45 - VK - 42 - 10×3	19.5	9 (± 1) (with brake)	27 (± 0.3) (with brake)	70.4 (± 1) (without brake) ; 106.4 (± 1) (with brake)	42.3

Dimensions

Designation	E6	E7	E8	E9	E10
MGBS 45 - MSD - 42 - 10×3	19.5	9 (± 1) (with brake)	27 (± 0.3) (with brake)	70.4 (± 1) (without brake) ; 106.4 (± 1) (with brake)	42.3
MGBS 45 - VK - 56 - 10×3	23	9 (± 1) (with brake)	12 (± 0.3) (with brake)	98 (± 1) (without brake) ; 138 (± 1) (with brake)	56.4
MGBS 45 - MSD - 56 - 10×3	23	9 (± 1) (with brake)	12 (± 0.3) (with brake)	98 (± 1) (without brake) ; 138 (± 1) (with brake)	56.4
MGBS 45 - 10×10	-	-	-	-	-
MGBS 45 - VK - 42 - 10×10	19.5	9 (± 1) (with brake)	27 (± 0.3) (with brake)	70.4 (± 1) (without brake) ; 106.4 (± 1) (with brake)	42.3
MGBS 45 - MSD - 42 - 10×10	19.5	9 (± 1) (with brake)	27 (± 0.3) (with brake)	70.4 (± 1) (without brake) ; 106.4 (± 1) (with brake)	42.3
MGBS 45 - VK - 56 - 10×10	23	9 (± 1) (with brake)	12 (± 0.3) (with brake)	98 (± 1) (without brake) ; 138 (± 1) (with brake)	56.4
MGBS 45 - MSD - 56 - 10×10	23	9 (± 1) (with brake)	12 (± 0.3) (with brake)	98 (± 1) (without brake) ; 138 (± 1) (with brake)	56.4
MGBS 60 - 12×5	-	-	-	-	-
MGBS 60 - VK - 56 - 12×5	23	9 (± 1) (with brake)	12 (± 0.3) (with brake)	98 (± 1) (without brake) ; 138 (± 1) (with brake)	56.4
MGBS 60 - MSD - 56 - 12×5	23	9 (± 1) (with brake)	12 (± 0.3) (with brake)	98 (± 1) (without brake) ; 138 (± 1) (with brake)	56.4
MGBS 60 - VK - 86 - 12×5	Currently not available	Currently not available	Currently not available	Currently not available	Currently not available
MGBS 60 - MSD - 86 - 12×5	Currently not available	Currently not available	Currently not available	Currently not available	Currently not available
MGBS 60 - 12×10	-	-	-	-	-

Dimensions

Designation	E6	E7	E8	E9	E10
MGBS 60 - VK - 56 - 12×10	23	9 (± 1) (with brake)	12 (± 0.3) (with brake)	98 (± 1) (without brake) ; 138 (± 1) (with brake)	56.4
MGBS 60 - MSD - 56 - 12×10	23	9 (± 1) (with brake)	12 (± 0.3) (with brake)	98 (± 1) (without brake) ; 138 (± 1) (with brake)	56.4
MGBS 60 - VK - 86 - 12×10	Currently not available	Currently not available	Currently not available	Currently not available	Currently not available
MGBS 60 - MSD - 86 - 12×10	Currently not available	Currently not available	Currently not available	Currently not available	Currently not available

Drive Data

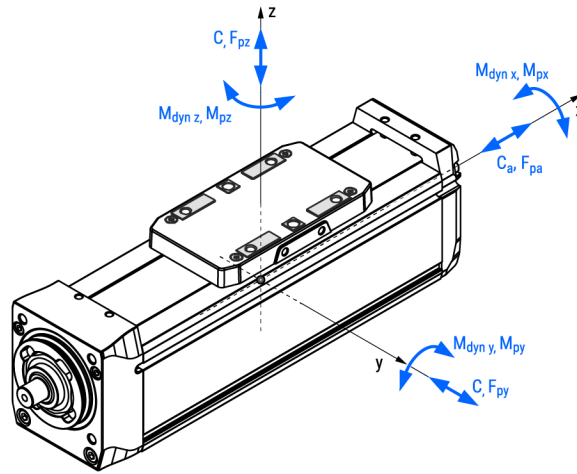

Designation	Description	Ball Screw (d x l)	Motor Type	Motor Size (mm)	Max. Permissible Axial Load Fpa (N)
MGBS 32 - 8x2	Without a motor	8 x 2	-	-	285
MGBS 32 - VK - 28 - 8x2	With motor size 28 and motor adapter VK	8 x 2	Stepper	28	200
MGBS 32 - MSD - 28 - 8x2	With motor size 28 and motor side drive MSD	8 x 2	Stepper	28	160
MGBS 32 - VK - 42 - 8x2	With motor size 42 and motor adapter VK	8 x 2	Stepper	42	285
MGBS 32 - MSD - 42 - 8x2	With motor size 42 and motor side drive MSD	8 x 2	Stepper	42	285
MGBS 32 - 8x8	Without a motor	8 x 8	-	-	285
MGBS 32 - VK - 28 - 8x8	With motor size 28 and motor adapter VK	8 x 8	Stepper	28	50
MGBS 32 - MSD - 28 - 8x8	With motor size 28 and motor side drive MSD	8 x 8	Stepper	28	40
MGBS 32 - VK - 42 - 8x8	With motor size 42 and motor adapter VK	8 x 8	Stepper	42	200
MGBS 32 - MSD - 42 - 8x8	With motor size 42 and motor side drive MSD	8 x 8	Stepper	42	175
MGBS 45 - 10x3	Without a motor	10 x 3	-	-	695
MGBS 45 - VK - 42 - 10x3	With motor size 42 and motor adapter VK	10 x 3	Stepper	42	395
MGBS 45 - MSD - 42 - 10x3	With motor size 42 and motor side drive MSD	10 x 3	Stepper	42	330
MGBS 45 - VK - 56 - 10x3	With motor size 56 and motor side drive MSD	10 x 3	Stepper	56	695
MGBS 45 - MSD - 56 - 10x3	With motor size 56 and motor side drive MSD	10 x 3	Stepper	56	695

Drive Data

Designation	Description	Ball Screw (d x l)	Motor Type	Motor Size (mm)	Max. Permissible Axial Load Fpa (N)
MGBS 45 - 10x10	Without a motor	10 x 10	-	-	695
MGBS 45 - VK - 42 - 10x10	With motor size 42 and motor adapter VK	10 x 10	Stepper	42	120
MGBS 45 - MSD - 42 - 10x10	With motor size 42 and motor side drive MSD	10 x 10	Stepper	42	110
MGBS 45 - VK - 56 - 10x10	With motor size 56 and motor side drive MSD	10 x 10	Stepper	56	570
MGBS 45 - MSD - 56 - 10x10	With motor size 56 and motor side drive MSD	10 x 10	Stepper	56	450
MGBS 60 - 12x5	Without a motor	12 x 5	-	-	1100
MGBS 60 - VK - 56 - 12x5	With motor size 56 and motor side drive MSD	12 x 5	Stepper	56	1030
MGBS 60 - MSD - 56 - 12x5	With motor size 56 and motor side drive MSD	12 x 5	Stepper	56	900
MGBS 60 - VK - 86 - 12x5	With motor size 86 and motor side drive MSD	12 x 5	Stepper	86	Currently not available
MGBS 60 - MSD - 86 - 12x5	With motor size 86 and motor side drive MSD	12 x 5	Stepper	86	Currently not available
MGBS 60 - 12x10	Without a motor	12 x 10	-	-	1100
MGBS 60 - VK - 56 - 12x10	With motor size 56 and motor side drive MSD	12 x 10	Stepper	56	525
MGBS 60 - MSD - 56 - 12x10	With motor size 56 and motor side drive MSD	12 x 10	Stepper	56	450
MGBS 60 - VK - 86 - 12x10	With motor size 86 and motor side drive MSD	12 x 10	Stepper	86	Currently not available
MGBS 60 - MSD - 86 - 12x10	With motor size 86 and motor side drive MSD	12 x 10	Stepper	86	Currently not available

Designation	Max. Permissible Payload Horizontal mph (kg)	Max. Permissible Payload Vertical mpv (kg)	Max. Drive Torque M _p (Nm)	No Load Torque M _o (Nm)	Max. Permissible Radial Load on Shaft Fpr (N)	Max. Travel Speed Vmax (m/s)
MGBS 32 - 8x2	31	24	0.10	0.04	50	0.150
MGBS 32 - VK - 28 - 8x2	31	17	-	-	-	0.093
MGBS 32 - MSD - 28 - 8x2	31	13	-	-	-	0.064
MGBS 32 - VK - 42 - 8x2	31	24	-	-	-	0.100
MGBS 32 - MSD - 42 - 8x2	31	24	-	-	-	0.100
MGBS 32 - 8x8	31	24	0.40	0.05	50	0.600
MGBS 32 - VK - 28 - 8x8	6.2	4.1	-	-	-	0.300
MGBS 32 - MSD - 28 - 8x8	6.3	3.3	-	-	-	0.208
MGBS 32 - VK - 42 - 8x8	31	17	-	-	-	0.400

Drive Data

Designation	Max. Permissible Payload Horizontal mph (kg)	Max. Permissible Payload Vertical mpv (kg)	Max. Drive Torque M_p (Nm)	No Load Torque M_0 (Nm)	Max. Permissible Radial Load on Shaft Fpr (N)	Max. Travel Speed V_{max} (m/s)
MGBS 32 - MSD - 42 - 8×8	31	15	-	-	-	0.400
MGBS 45 - 10×3	71	59	0.37	0.10	100	0.225
MGBS 45 - VK - 42 - 10×3	71	33	-	-	-	0.146
MGBS 45 - MSD - 42 - 10×3	71	28	-	-	-	0.137
MGBS 45 - VK - 56 - 10×3	71	59	-	-	-	0.150
MGBS 45 - MSD - 56 - 10×3	71	59	-	-	-	0.150
MGBS 45 - 10×10	71	59	1.23	0.11	100	0.750
MGBS 45 - VK - 42 - 10×10	20	10	-	-	-	0.477
MGBS 45 - MSD - 42 - 10×10	19	9	-	-	-	0.410
MGBS 45 - VK - 56 - 10×10	71	48	-	-	-	0.500
MGBS 45 - MSD - 56 - 10×10	71	38	-	-	-	0.500
MGBS 60 - 12×5	204	93	0.97	0.16	200	0.483
MGBS 60 - VK - 56 - 12×5	204	87	-	-	-	0.250
MGBS 60 - MSD - 56 - 12×5	204	76	-	-	-	0.250
MGBS 60 - VK - 86 - 12×5	Currently not available	Currently not available	-	-	-	Currently not available
MGBS 60 - MSD - 86 - 12×5	Currently not available	Currently not available	-	-	-	Currently not available
MGBS 60 - 12×10	204	93	1.95	0.17	200	0.967
MGBS 60 - VK - 56 - 12×10	127	44	-	-	-	0.500
MGBS 60 - MSD - 56 - 12×10	126	38	-	-	-	0.500
MGBS 60 - VK - 86 - 12×10	Currently not available	Currently not available	-	-	-	Currently not available
MGBS 60 - MSD - 86 - 12×10	Currently not available	Currently not available	-	-	-	Currently not available

Designation	Max. Rotational Speed (rev/min)	Max. Acceleration (m/s ²)
MGBS 32 - 8×2	4500	20
MGBS 32 - VK - 28 - 8×2	2800	16
MGBS 32 - MSD - 28 - 8×2	1920	16
MGBS 32 - VK - 42 - 8×2	3000	20
MGBS 32 - MSD - 42 - 8×2	3000	20
MGBS 32 - 8×8	4500	20
MGBS 32 - VK - 28 - 8×8	2250	20
MGBS 32 - MSD - 28 - 8×8	1560	20
MGBS 32 - VK - 42 - 8×8	3000	20
MGBS 32 - MSD - 42 - 8×8	3000	20
MGBS 45 - 10×3	4500	20
MGBS 45 - VK - 42 - 10×3	2920	20
MGBS 45 - MSD - 42 - 10×3	2740	13
MGBS 45 - VK - 56 - 10×3	3000	20
MGBS 45 - MSD - 56 - 10×3	3000	20

Drive Data

Designation	Max. Rotational Speed (rev/min)	Max. Acceleration (m/s ²)
MGBS 45 - 10×10	4500	20
MGBS 45 - VK - 42 - 10×10	2860	20
MGBS 45 - MSD - 42 - 10×10	2460	20
MGBS 45 - VK - 56 - 10×10	3000	20
MGBS 45 - MSD - 56 - 10×10	3000	20
MGBS 60 - 12×5	5800	20
MGBS 60 - VK - 56 - 12×5	3000	20
MGBS 60 - MSD - 56 - 12×5	3000	20
MGBS 60 - VK - 86 - 12×5	Currently not available	20
MGBS 60 - MSD - 86 - 12×5	Currently not available	20
MGBS 60 - 12×10	5800	20
MGBS 60 - VK - 56 - 12×10	3000	20
MGBS 60 - MSD - 56 - 12×10	3000	20
MGBS 60 - VK - 86 - 12×10	Currently not available	20
MGBS 60 - MSD - 86 - 12×10	Currently not available	20

Mass and Mass Moment of Inertia

Designation	Description	Ball Screw (d x l)	Moved Mass (kg)	Mass of Linear Unit (kg)	Mass Moment of Inertia JMGBS (10 ⁻² kg cm ²)
MGBS 32 - 8x2	Without a motor	8 x 2	0.12	0.36 + 0.0015 x Abs. Stroke	0.85 + 0.0024 x Abs. Stroke + 0.1013 x mload
MGBS 32 - VK - 28 - 8x2	With motor size 28 and motor adapter VK	8 x 2	0.12	0.36 + 0.0015 x Abs. Stroke	0.85 + 0.0024 x Abs. Stroke + 0.1013 x mload
MGBS 32 - MSD - 28 - 8x2	With motor size 28 and motor side drive MSD	8 x 2	0.12	0.36 + 0.0015 x Abs. Stroke	0.85 + 0.0024 x Abs. Stroke + 0.1013 x mload
MGBS 32 - VK - 42 - 8x2	With motor size 42 and motor adapter VK	8 x 2	0.12	0.36 + 0.0015 x Abs. Stroke	0.85 + 0.0024 x Abs. Stroke + 0.1013 x mload
MGBS 32 - MSD - 42 - 8x2	With motor size 42 and motor side drive MSD	8 x 2	0.12	0.36 + 0.0015 x Abs. Stroke	0.85 + 0.0024 x Abs. Stroke + 0.1013 x mload
MGBS 32 - 8x8	Without a motor	8 x 8	0.12	0.36 + 0.0015 x Abs. Stroke	1.04 + 0.0025 x Abs. Stroke + 1.6211 x mload
MGBS 32 - VK - 28 - 8x8	With motor size 28 and motor adapter VK	8 x 8	0.12	0.36 + 0.0015 x Abs. Stroke	1.04 + 0.0025 x Abs. Stroke + 1.6211 x mload
MGBS 32 - MSD - 28 - 8x8	With motor size 28 and motor side drive MSD	8 x 8	0.12	0.36 + 0.0015 x Abs. Stroke	1.04 + 0.0025 x Abs. Stroke + 1.6211 x mload
MGBS 32 - VK - 42 - 8x8	With motor size 42 and motor adapter VK	8 x 8	0.12	0.36 + 0.0015 x Abs. Stroke	1.04 + 0.0025 x Abs. Stroke + 1.6211 x mload
MGBS 32 - MSD - 42 - 8x8	With motor size 42 and motor side drive MSD	8 x 8	0.12	0.36 + 0.0015 x Abs. Stroke	1.04 + 0.0025 x Abs. Stroke + 1.6211 x mload
MGBS 45 - 10x3	Without a motor	10 x 3	0.23	0.80 + 0.0028 x Abs. Stroke	3.17 + 0.0055 x Abs. Stroke + 0.2280 x mload
MGBS 45 - VK - 42 - 10x3	With motor size 42 and motor adapter VK	10 x 3	0.23	0.80 + 0.0028 x Abs. Stroke	3.17 + 0.0055 x Abs. Stroke + 0.2280 x mload
MGBS 45 - MSD - 42 - 10x3	With motor size 42 and motor side drive MSD	10 x 3	0.23	0.80 + 0.0028 x Abs. Stroke	3.17 + 0.0055 x Abs. Stroke + 0.2280 x mload
MGBS 45 - VK - 56 - 10x3	With motor size 56 and motor side drive MSD	10 x 3	0.23	0.80 + 0.0028 x Abs. Stroke	3.17 + 0.0055 x Abs. Stroke + 0.2280 x mload
MGBS 45 - MSD - 56 - 10x3	With motor size 56 and motor side drive MSD	10 x 3	0.23	0.80 + 0.0028 x Abs. Stroke	3.17 + 0.0055 x Abs. Stroke + 0.2280 x mload
MGBS 45 - 10x10	Without a motor	10 x 10	0.23	0.80 + 0.0028 x Abs. Stroke	3.72 + 0.0056 x Abs. Stroke + 2.5330 x mload
MGBS 45 - VK - 42 - 10x10	With motor size 42 and motor adapter VK	10 x 10	0.23	0.80 + 0.0028 x Abs. Stroke	3.72 + 0.0056 x Abs. Stroke + 2.5330 x mload
MGBS 45 - MSD - 42 - 10x10	With motor size 42 and motor side drive MSD	10 x 10	0.23	0.80 + 0.0028 x Abs. Stroke	3.72 + 0.0056 x Abs. Stroke + 2.5330 x mload

Mass and Mass Moment of Inertia

Designation	Description	Ball Screw (d x l)	Moved Mass (kg)	Mass of Linear Unit (kg)	Mass Moment of Inertia JMGBS (10 ⁻² kg cm ²)
MGBS 45 - VK - 56 - 10x10	With motor size 56 and motor side drive MSD	10 x 10	0.23	0.80 + 0.0028 x Abs. Stroke	3.72 + 0.0056 x Abs. Stroke + 2.5330 x mload
MGBS 45 - MSD - 56 - 10x10	With motor size 56 and motor side drive MSD	10 x 10	0.23	0.80 + 0.0028 x Abs. Stroke	3.72 + 0.0056 x Abs. Stroke + 2.5330 x mload
MGBS 60 - 12x5	Without a motor	12 x 5	0.53	1.80 + 0.0049 x Abs. Stroke	11.04 + 0.0132 x Abs. Stroke + 0.6333 x mload
MGBS 60 - VK - 56 - 12x5	With motor size 56 and motor side drive MSD	12 x 5	0.53	1.80 + 0.0049 x Abs. Stroke	11.04 + 0.0132 x Abs. Stroke + 0.6333 x mload
MGBS 60 - MSD - 56 - 12x5	With motor size 56 and motor side drive MSD	12 x 5	0.53	1.80 + 0.0049 x Abs. Stroke	11.04 + 0.0132 x Abs. Stroke + 0.6333 x mload
MGBS 60 - VK - 86 - 12x5	With motor size 86 and motor side drive MSD	12 x 5	0.53	1.80 + 0.0049 x Abs. Stroke	11.04 + 0.0132 x Abs. Stroke + 0.6333 x mload
MGBS 60 - MSD - 86 - 12x5	With motor size 86 and motor side drive MSD	12 x 5	0.53	1.80 + 0.0049 x Abs. Stroke	11.04 + 0.0132 x Abs. Stroke + 0.6333 x mload
MGBS 60 - 12x10	Without a motor	12 x 10	0.53	1.80 + 0.0049 x Abs. Stroke	11.97 + 0.0126 x Abs. Stroke + 2.5330 x mload
MGBS 60 - VK - 56 - 12x10	With motor size 56 and motor side drive MSD	12 x 10	0.53	1.80 + 0.0049 x Abs. Stroke	11.97 + 0.0126 x Abs. Stroke + 2.5330 x mload
MGBS 60 - MSD - 56 - 12x10	With motor size 56 and motor side drive MSD	12 x 10	0.53	1.80 + 0.0049 x Abs. Stroke	11.97 + 0.0126 x Abs. Stroke + 2.5330 x mload
MGBS 60 - VK - 86 - 12x10	With motor size 86 and motor side drive MSD	12 x 10	0.53	1.80 + 0.0049 x Abs. Stroke	11.97 + 0.0126 x Abs. Stroke + 2.5330 x mload
MGBS 60 - MSD - 86 - 12x10	With motor size 86 and motor side drive MSD	12 x 10	0.53	1.80 + 0.0049 x Abs. Stroke	11.97 + 0.0126 x Abs. Stroke + 2.5330 x mload

Designation	Mass of the motor and motor adapter VK (kg)	Mass of the motor and motor side drive MSD (kg)	Planar Moment of Inertia Iy (cm ⁴)	Planar Moment of Inertia Iz (cm ⁴)	Holding Torque Motor Brake (Nm)
MGBS 32 - 8x2	-	-	4.3	4.6	-
MGBS 32 - VK - 28 - 8x2	Currently not available	-	4.3	4.6	Currently not available
MGBS 32 - MSD - 28 - 8x2	-	Currently not available	4.3	4.6	Currently not available
MGBS 32 - VK - 42 - 8x2	0.52 without brake ; 0.65 with brake	-	4.3	4.6	0.4
MGBS 32 - MSD - 42 - 8x2	-	0.62 without brake ; 0.75 with brake	4.3	4.6	0.4
MGBS 32 - 8x8	-	-	4.3	4.6	-
MGBS 32 - VK - 28 - 8x8	Currently not available	-	4.3	4.6	Currently not available
MGBS 32 - MSD - 28 - 8x8	-	Currently not available	4.3	4.6	Currently not available

Mass and Mass Moment of Inertia

Designation	Mass of the motor and motor adapter VK (kg)	Mass of the motor and motor side drive MSD (kg)	Planar Moment of Inertia I _y (cm ⁴)	Planar Moment of Inertia I _z (cm ⁴)	Holding Torque Motor Brake (Nm)
MGBS 32 - VK - 42 - 8×8	0.52 without brake ; 0.65 with brake	-	4.3	4.6	0.4
MGBS 32 - MSD - 42 - 8×8	-	0.62 without brake ; 0.75 with brake	4.3	4.6	0.4
MGBS 45 - 10×3	-	-	14.3	15.9	-
MGBS 45 - VK - 42 - 10×3	0.57 without brake ; 0.70 with brake	-	14.3	15.9	0.4
MGBS 45 - MSD - 42 - 10×3	-	0.71 without brake ; 0.84 with brake	14.3	15.9	0.4
MGBS 45 - VK - 56 - 10×3	1.31 without brake ; 1.50 with brake	-	14.3	15.9	1.0
MGBS 45 - MSD - 56 - 10×3	-	1.49 without brake ; 1.68 with brake	14.3	15.9	1.0
MGBS 45 - 10×10	-	-	14.3	15.9	-
MGBS 45 - VK - 42 - 10×10	0.57 without brake ; 0.70 with brake	-	14.3	15.9	0.4
MGBS 45 - MSD - 42 - 10×10	-	0.71 without brake ; 0.84 with brake	14.3	15.9	0.4
MGBS 45 - VK - 56 - 10×10	1.31 without brake ; 1.50 with brake	-	14.3	15.9	1.0
MGBS 45 - MSD - 56 - 10×10	-	1.49 without brake ; 1.68 with brake	14.3	15.9	1.0
MGBS 60 - 12×5	-	-	43.8	50.3	-
MGBS 60 - VK - 56 - 12×5	1.50 without brake ; 1.69 with brake	-	43.8	50.3	1.0
MGBS 60 - MSD - 56 - 12×5	-	1.73 without brake ; 1.92 with brake	43.8	50.3	1.0
MGBS 60 - VK - 86 - 12×5	Currently not available	-	43.8	50.3	Currently not available
MGBS 60 - MSD - 86 - 12×5	-	Currently not available	43.8	50.3	Currently not available
MGBS 60 - 12×10	-	-	43.8	50.3	-
MGBS 60 - VK - 56 - 12×10	1.50 without brake ; 1.69 with brake	-	43.8	50.3	1.0
MGBS 60 - MSD - 56 - 12×10	-	1.73 without brake ; 1.92 with brake	43.8	50.3	1.0
MGBS 60 - VK - 86 - 12×10	Currently not available	-	43.8	50.3	Currently not available
MGBS 60 - MSD - 86 - 12×10	-	Currently not available	43.8	50.3	Currently not available