

Linear Unit MRJ 110

The MRJ linear units have toothed belt drive and compact dimensions to provide high performance features such as high speed and good accuracy. For very high speeds, up to 10 m/s, the track rollers (journal bearings) of the type MRJ are particularly suitable.

The unit MRJ have a pre-tensioned steel reinforced AT polyurethane timing toothed belt.

In conjunction with a zero-backlash drive pulley high moments with alternating loads with good positioning accuracy, low wear and low noise can be realized.

All parts in the profile are protected from dust and other contaminations. As corrosion-resistant protection strip is available as option.

Dimensions in mm.

Modulus of Elasticity: $E = 70000 \text{ N / mm}^2$

Operating Temperature (°C): 0 ~ +60 For operating temperature out of the presented range, please contact Rollco.

Duty Cycle: 100%

Max. Acceleration (m/s²): 50 (Optional, acceleration up to 70 m/s² possible if used without INOX seal strip)

Max. Travel Speed (m/s): 1.5 (Optional, travel speed up to 10 m/s possible if used without INOX seal strip)

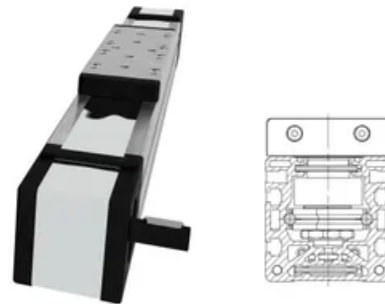



1. Drive block with pulley
2. Corrosion-resistant protection strip (available also without protection strip)
3. AT polyurethane toothed belt with steel tension cords
4. Carriage with build in magnets
5. Aluminium profile-hard anodized
6. Track roller (journal bearing)
7. Two hardened steel round guide (58/60 HRC)
8. Central lubrication port, both sides
9. Tension end with integrated belt tensioning system

Deflection of the linear unit

Fixed - fixed mounting

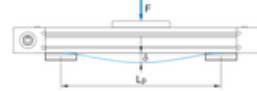

Fixed - free mounting

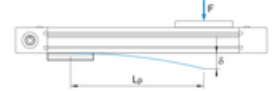

δ Maximum deflection of the linear unit [mm]
 δ_{max} Maximum permissible deflection of the linear unit [mm]
 F Applied force [N]
 L_p Unsupported profile length [mm]

The maximum permissible deflection δ_{max} must not be exceeded. In the case that maximum deflection δ exceeds the maximum permissible deflection δ_{max} additional profile supports are needed.

Deflection of the linear unit

MRJ 110

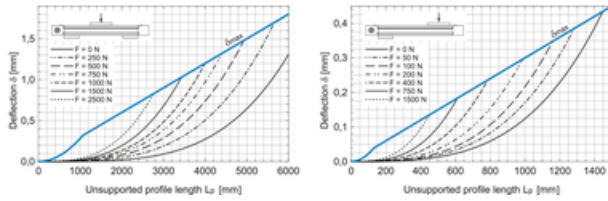

① The linear units do not include any safety stroke.
 Absolute stroke = Effective stroke + 2 x safety stroke.

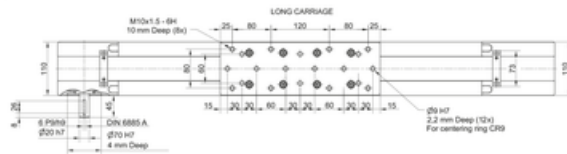

① Journal with or without keyway ① All dimensions in mm. Drawings scales are not equal

① The linear units do not include any safety stroke.
 Absolute stroke = Effective stroke + 2 x safety stroke.

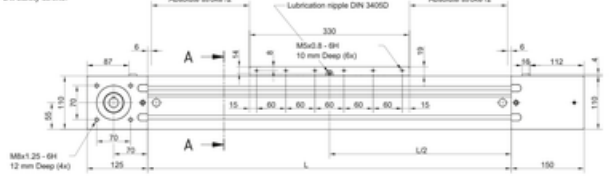

① Journal with or without keyway ① All dimensions in mm. Drawings scales are not equal

① The linear units do not include any safety stroke.
 Absolute stroke = Effective stroke + 2 x safety stroke.



① Short carriage only for MJ series

① Journal with or without keyway ① All dimensions in mm. Drawings scales are not equal

TYPE 0

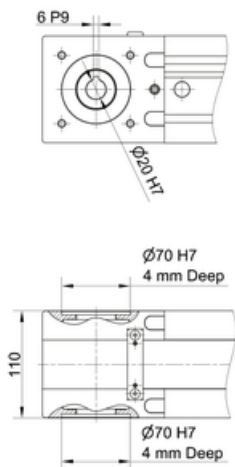

TYPE 1 L and 1 R

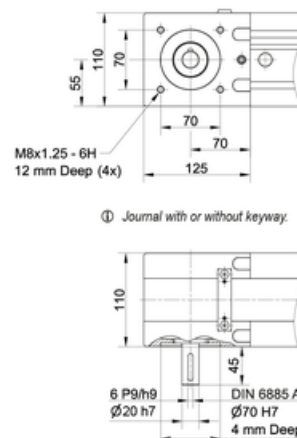

① Journal with or without keyway.

TYPE 2

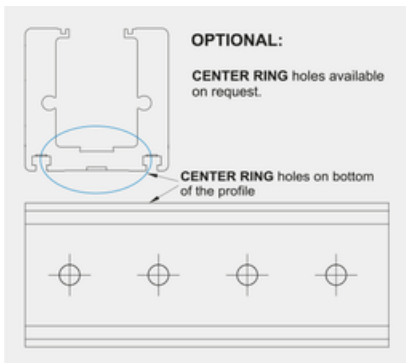
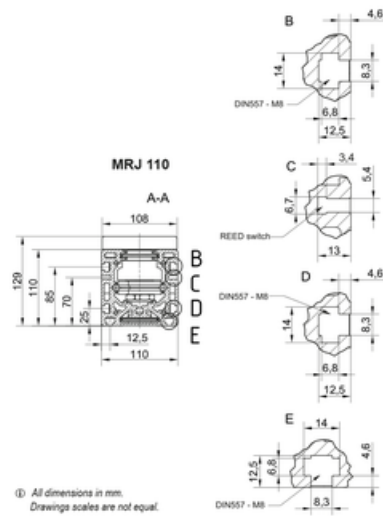
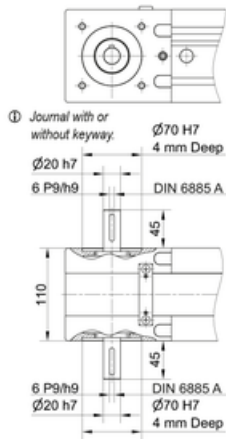

Defining of the linear unit length

$$L = \text{Effective stroke} + 2 \times \text{Safety stroke} + L_v + 12 \text{ mm}$$

$$L_v - \text{Long carriage} = 330 \text{ mm}$$

$$L_{\text{total}} = L + 275 \text{ mm}$$

$$L_v - \text{Short carriage} = 240 \text{ mm}$$

Left side (L)

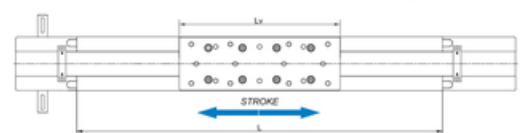

Double Carriage

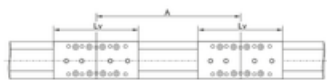

$$L = \text{Effective stroke} + 2 \times \text{Safety stroke} + L_v + A + 12 \text{ mm}$$

$$L_{\text{total}} = L + 275 \text{ mm}$$

$A \geq L_v$

General data

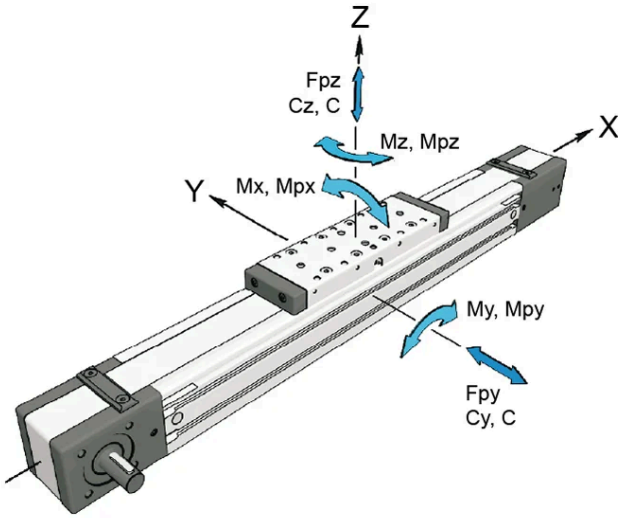

For lengths/stroke over the stated value in the table, please contact Rollco. Values for max. stroke are not valid for double carriage (equation of defining the linear unit length for particular size of the linear unit needs to be used).

For minimum stroke below the stated value in the table, please contact Rollco.

Recommended values of loads

All the data of static and dynamic moments and load capacities stated in the table are theoretical without considering any safety factor. The safety factor depends on the application and its requested safety. We recommend a minimum safety factor ($f_s = 5.0$).

Modulus of elasticity

$E = 70000 \text{ N / mm}^2$

Designation	Carriage Length L_v (mm)	Load Capacity C_y (N)	Load Capacity C_z (N)	Dynamic Moment M_x (Nm)	Dynamic Moment M_y (Nm)
MRJ 110 L	330	31000	14000	406	877

Designation	Dynamic Moment M_z (Nm)	Dynamic Load Capacity C (N)	Static Load Capacity C_0 (N)	Max. Permissible Loads Forces F_{py} (N)	Max. Permissible Loads Forces F_{pz} (N)	Max. Permissible Loads Moments M_{px} (Nm)
MRJ 110 L	2325	31000	14000	6200	3410	99

Designation	Max. Permissible Loads Moments M_{py} (Nm)	Max. Permissible Loads Moments M_{pz} (Nm)	Moved Mass (kg)	Max. Repeatability (mm)	Max. Length L_{max} (mm)	Max. Stroke (mm)
MRJ 110 L	214	465	4.78	± 0.08	6000	5658

Designation	Min. Stroke (mm)
MRJ 110 L	0

General data double carriage

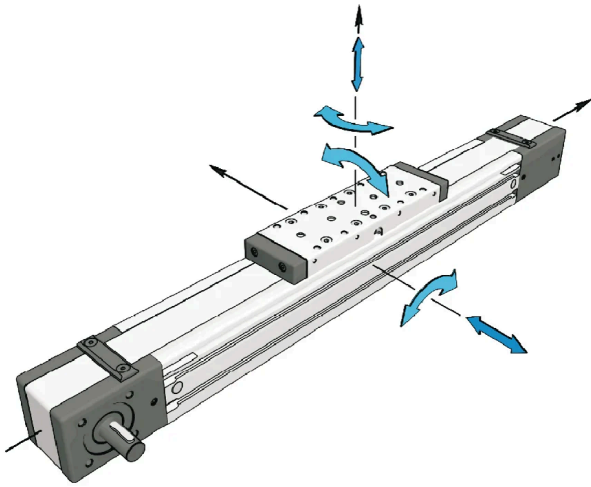

A - Distance between carriages.

Max. travel speed and max. acceleration of linear unit with the corrosion-resistant protection strip is 1,5 m/s and 50 m/s² respectively.

The stated values are for strokes up to 500 mm. No load torque value increases with stroke elongation.

Max. acceleration (m/s²): 70

For acceleration over the stated value, please contact Rollco.

Designation	Carriage version	Load Capacity Cy (N)	Load Capacity Cz (N)	Dynamic Moment Mx (Nm)	Dynamic Moment My (Nm)
MRJ 110 L	L2	62000	28000	812	14.0 × A (mm)

Designation	Dynamic Moment Mz (Nm)	Max. Permissible Loads Forces Fpy (N)	Max. Permissible Loads Forces Fpz (N)	Max. Permissible Loads Moments Mpx (Nm)	Max. Permissible Loads Moments Mpy (Nm)	Max. Permissible Loads Moments Mpz (Nm)
MRJ 110 L	31.0 × A (mm)	12400	6830	198	3.4 × A (mm)	6.2 × A (mm)

Drive data

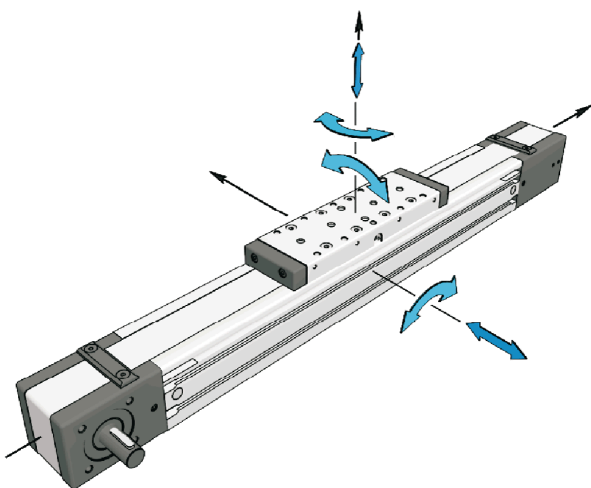

Max. travel speed and max. acceleration of linear unit with the corrosion-resistant protection strip is 1,5 m/s and 50 m/s² respectively.

The stated values are for strokes up to 500 mm. No load torque value increases with stroke elongation.

Max. acceleration (m/s²): 70

For acceleration over the stated value, please contact Rollco.

Mass calculation does not include mass of motor, reduction gear, switches and clamps.

Abs. stroke	Absolute stroke [mm]
A	Distance between carriages [mm]
nc	Number of carriages

Designation	Max. Drive Torque Ma (Nm)	No Load Torque with Strip (Nm)	No Load Torque without Strip (Nm)	Pulley Drive Ratio (mm/rev)	Pulley Diameter
MRJ 110 L	68.5 with keyway / 82.6 without keyway	1.8	1.5	300	95.49

Designation	Belt Type	Belt Width	Max. Force Transmitted by Belt (N)	Specific Spring Constant Cspec (N)	Planar Moment of Inertia Iy (cm ⁴)	Planar Moment of Inertia Iz (cm ⁴)
MRJ 110 L	AT 10	50	1730	2145000	513	620

Mass and Mass moment

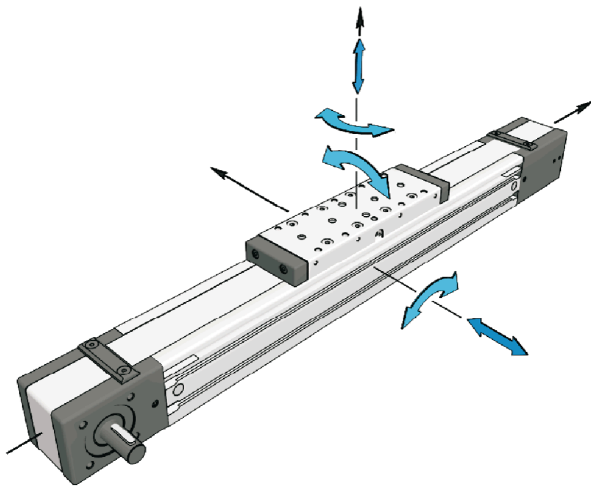

Max. travel speed and max. acceleration of linear unit with the corrosion-resistant protection strip is 1,5 m/s and 50 m/s² respectively.

The stated values are for strokes up to 500 mm. No load torque value increases with stroke elongation.

Max. acceleration (m/s²): 70

For acceleration over the stated value, please contact Rollco.

Mass calculation does not include mass of motor, reduction gear, switches and clamps.

Abs. stroke	Absolute stroke [mm]
A	Distance between carriages [mm]
nc	Number of carriages

Designation	Mass of Linear Unit (kg)	Mass Moment of Inertia (10 ⁻⁵ kg m ²)	Planar Moment of Inertia Iy (cm ⁴)	Planar Moment of Inertia Iz (cm ⁴)	Moved Mass (kg)
MRJ 110 L	16.3 + 0.0133 × (Abs. Stroke + (nc - 1) × A) + 4.78 × (nc - 1)	1420.0 + 0.137 × (Abs. Stroke + (nc - 1) × A) + 1089.6 × (nc - 1)	513	620	4.78