

## Conveyor Stand TB80 Multisystem

Aluminium profile stand to match Rollco Timing belt conveyors. Available with adjustable fixable feet. Configure your stand together with the timing belt conveyor in our CAD-configurator.

Values shown under "General data" indicates min and max values in mm according to our standard configurations. For other designs, please contact Rollco.



## General Data

Stand TB80 Multi Timing Belt Conveyor  
 $535 \leq E, D < 600$

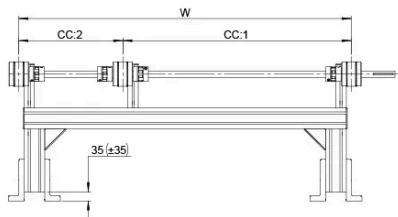
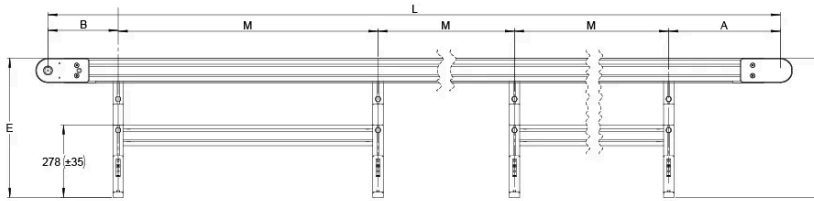

Stand TB80 Multi Timing Belt Conveyor  
 $600 \leq E, D \leq 900$

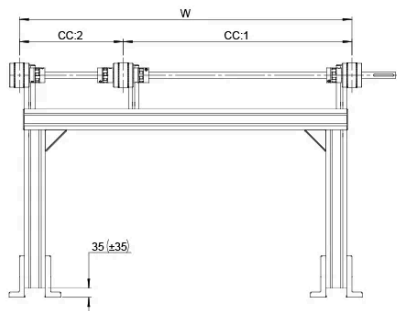
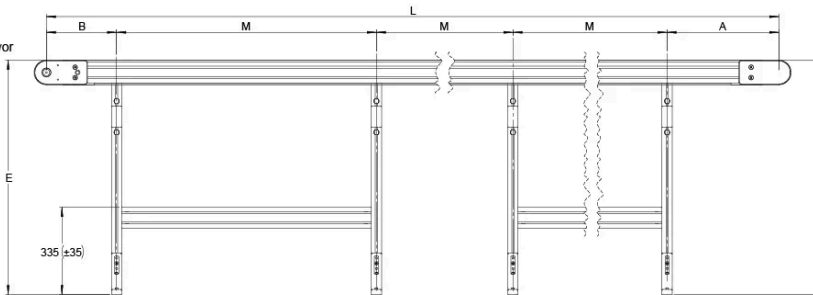

Stand TB80 Multi Timing Belt Conveyor  
 900 < E,D ≤ 1200

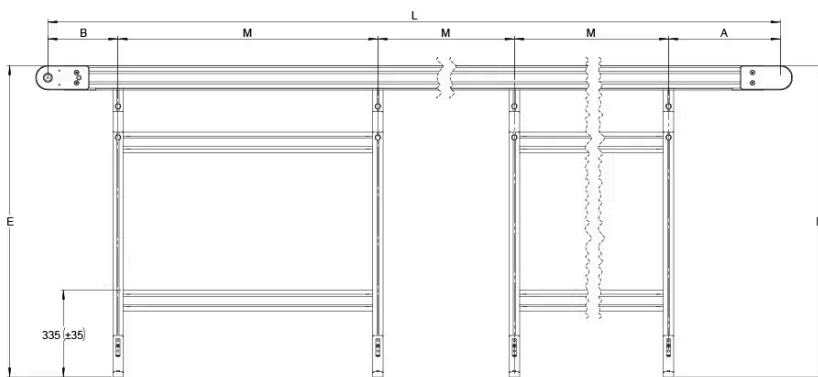

Stand TB80 Multi Timing Belt Conveyor  
 900 < E,D ≤ 1200

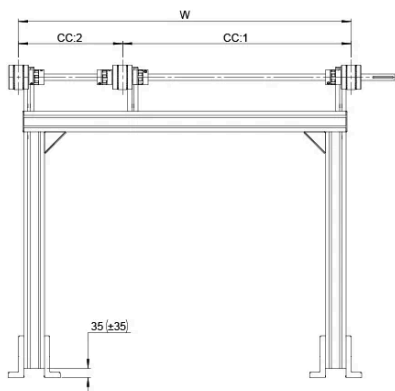

Designation	Profile Width	Profile Height	Total Length (L)	Total Width (W)	CC (w)
<b>TB80-multisystem-stand</b>	40	80	max 6000	max 6000	max 2000

Designation	No. of parallel units	A	B	D	E	M
<b>TB80-multisystem-stand</b>	3-10	210-500	210-250	535-1200	535-1200	160-1200