

Conveyor Stand TB40 Double

Aluminium profile stand to match Rollco Timing belt conveyors. Available with adjustable fixable feet. Configure your stand together with the timing belt conveyor in our CAD-configurator.

Values shown under "General data" indicates min and max values in mm according to our standard configurations. For other designs, please contact Rollco.



General Data

Stand TB40 Double Timing Belt Conveyor

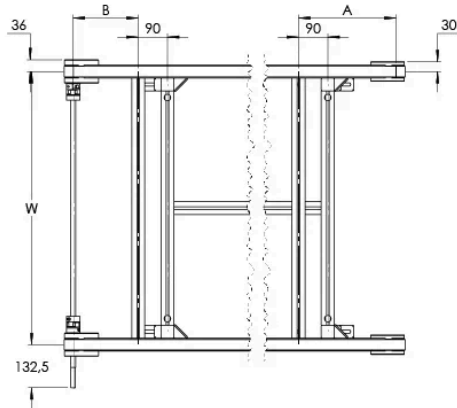

Stand TB40 Double Timing Belt Conveyor
 $390 \leq E, D \leq 650$

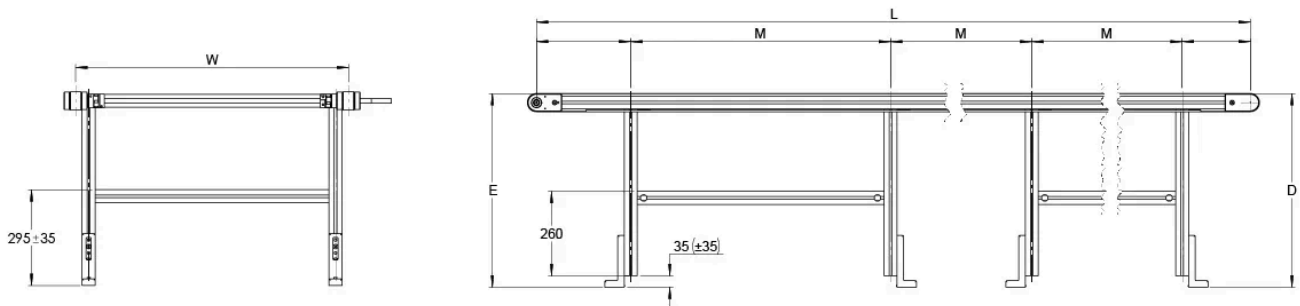

Stand TB40 Double Timing Belt Conveyor
650 < E,D ≤ 900

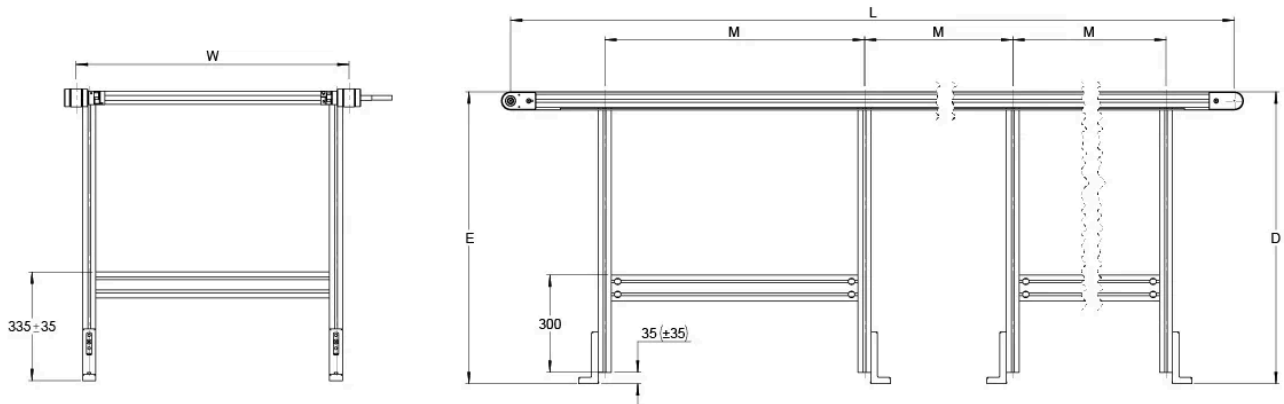

Stand TB40 Double Timing Belt Conveyor
900 < E,D ≤ 1200

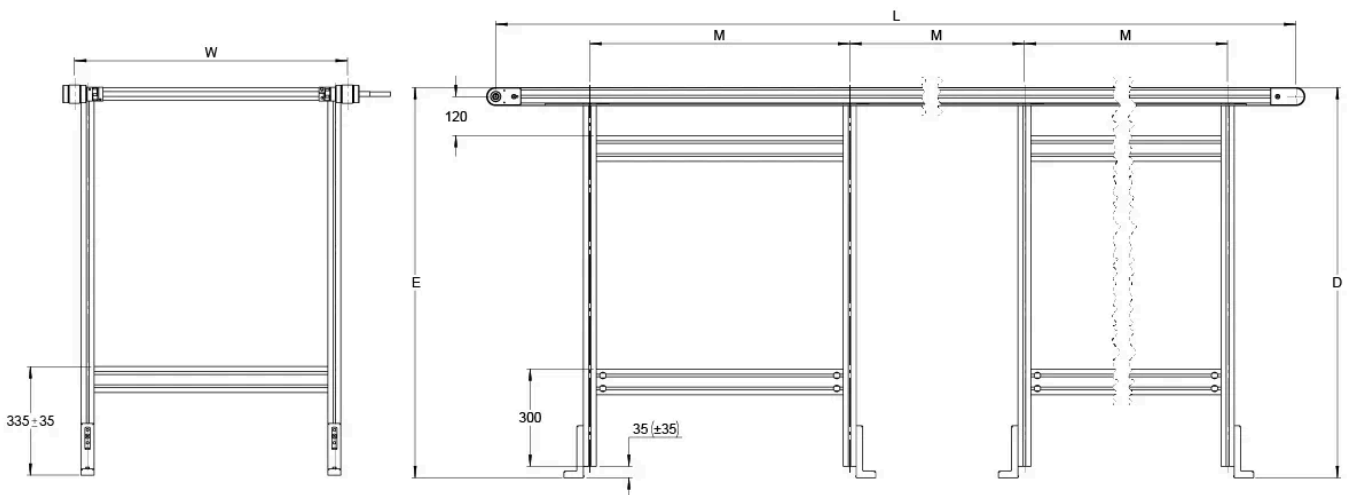

Designation	Profile Width	Profile Height	Total Length (L)	Total Width (W)	CC (w)
TB40-double-stand	40	40	max 6000	max 1500	max 1500

Designation	No. of parallell units	A	B	D	E	M
TB40-double-stand	2	235–390	100–110	390- 1200	390- 1200	160-1000