

Die-Cast Zinc Hinge with Oblong Holes, No Unhinging

Directly links to frameless surface elements and, by creating an articulated link between two profiles, allows surfaces with frames to connect to the base frame.

No unhinging.

Material: Wing: Die-cast zinc with a black powder coat; Pin: Stainless steel

On-site mount

Note: Use a notched slot nut to ensure that the connection is ESD-ready.

System: 30 - Slot 6

Type: Hinges

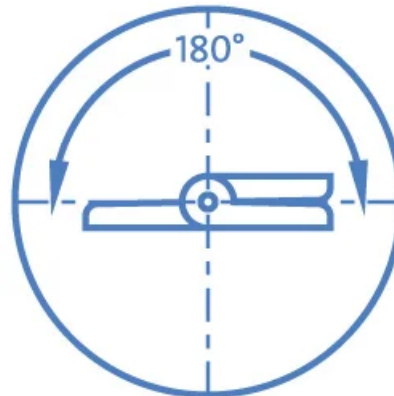

Die-Cast Zinc Hinge with Oblong Holes, No Unhinging

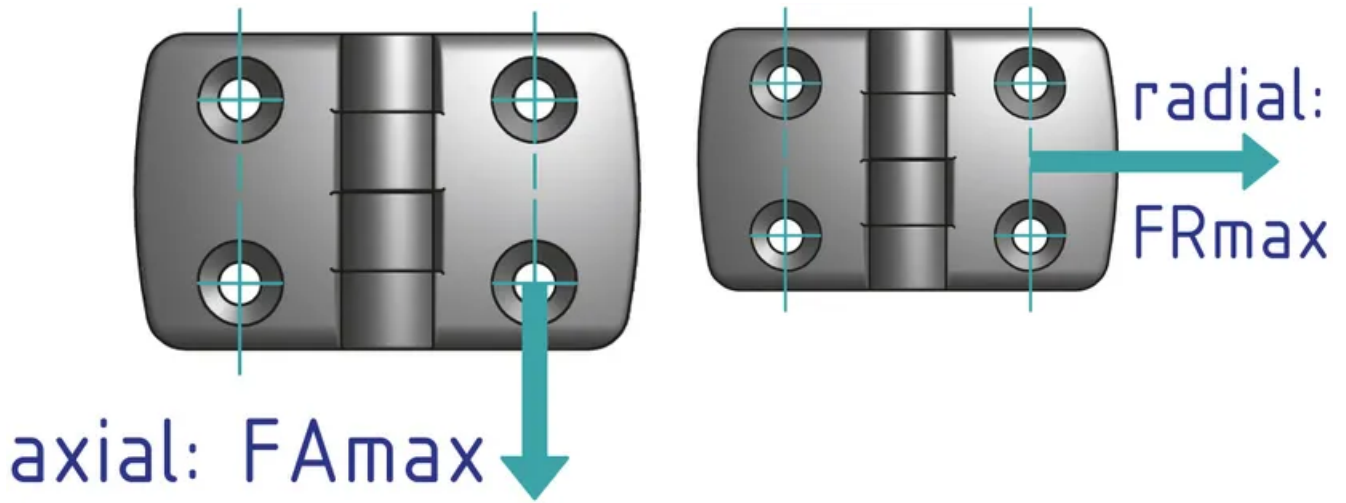

General Data

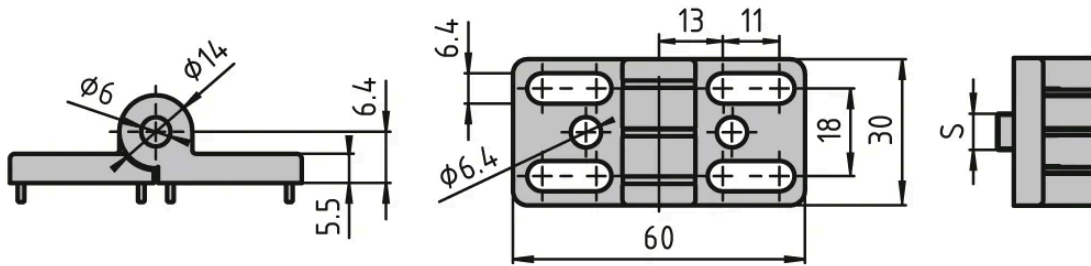

Designation	Description	System	F _{Amax} (N)	F _{Rmax} (N)
PZ3230	Hinge 30	30 - Slot 6	250	1000
PZ5114	Hinge 30	30 - Slot 6	350	1000