

BF80E

Belt conveyor with end drive. The product has a wide range of standard belts.

General load capacity for the BF80-family reaches up to 150 kg. Some combinations may give significantly less capacity, normally limited either by the available power or the belt traction capacity.

Dimension in mm.

For dimensions outside our standard range, please contact Rollco.

Use our CAD configurator to design your Belt conveyor according to your preferences and get a visual view, download data sheet and CAD files.

Declaration of incorporation of partly completed machinery according to Directive 2006/42/EC Annex II 1B.

Length (mm): Up to 6000

Gear ratio (I): 10 / 15 / 20 / 25 / 30 / 40 / 50 / 60 / 80 / 100

Speed (m/min): 36 (36.2) / 24 (24.3) / 18 (18.2) / 15 (14.5) / 12 (12.2) / 9 (9.3) / 7 (7.4) / 6 (6.1) / 5 (4.5) / 4 (3.7)

Drive side: Right/left

Motor Position: Horizontal/vertical — 1-4



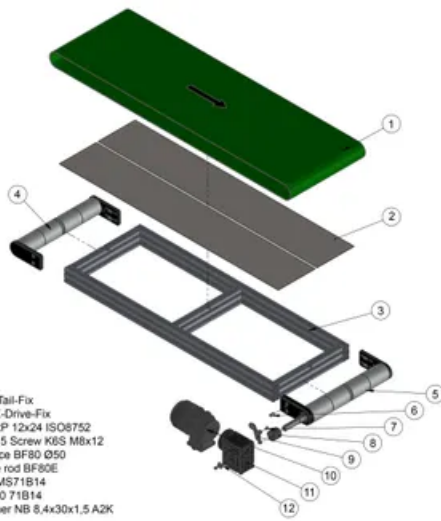

BF80E Drive holder

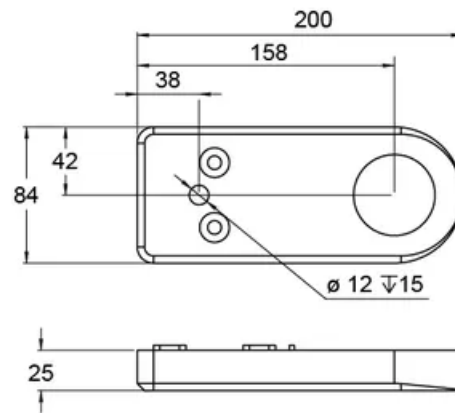

Gear ratio (I)	Speed (m/min)
10	36 (36,2)
15	24 (24,3)
20	18 (18,2)
25	15 (14,5)
30	12 (12,2)
40	9 (9,3)
50	7 (7,4)
60	6 (6,1)
80	5 (4,5)
100	4 (3,7)

General Data

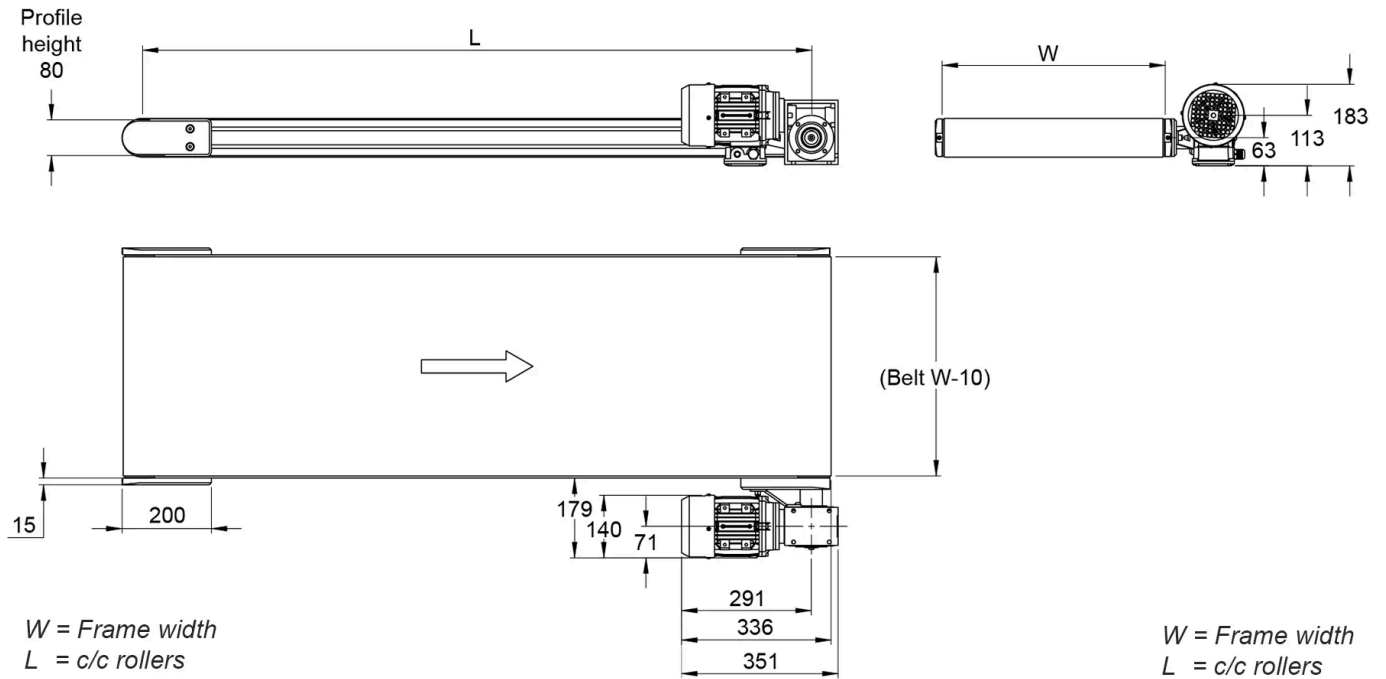

Designation	Width (mm)
BF80E - 500	500
BF80E - 600	600
BF80E - 700	700
BF80E - 800	800
BF80E - 900	900
BF80E - 1000	1000