

BF40EIK

Belt conveyor with end drive and knife edge in-feed. The product has a wide range of standard belts.

General load capacity for the BF40-family reaches up to 75 kg. Some combinations may give significantly less capacity, normally limited either by the available power or the belt traction capacity.

Dimension in mm.

For dimensions outside our standard range, please contact Rollco.

Use our CAD configurator to design your Belt conveyor according to your preferences and get a visual view, download data sheet and CAD files.

Declaration of incorporation of partly completed machinery according to Directive 2006/42/EC Annex II 1B.

Length (mm): Up to 4000

Gear ratio (I): 5 / 7.5 / 10 / 15 / 20 / 25 / 30 / 40 / 50

Speed (m/min): 37 (37.3) / 25 (24.9) / 19 (18.7) / 12 (12.4) / 9 (9.4) / 8 (7.5) / 6 (6.2) / 5 (4.7) / 4 (3.7)

Drive side: Right/left

Motor Position: Horizontal/vertical — 1-4



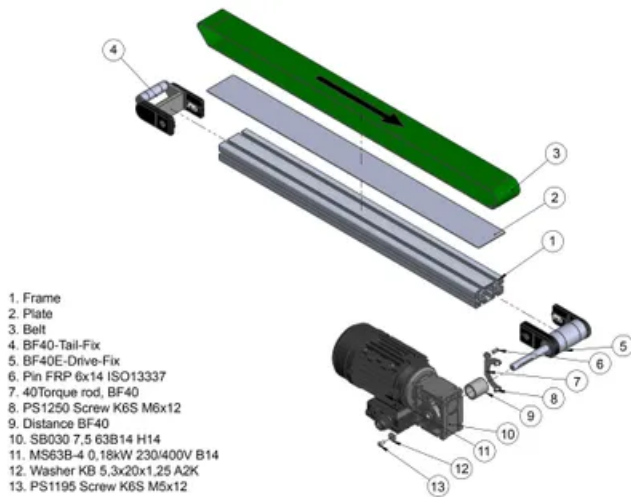

BF40E Drive holder

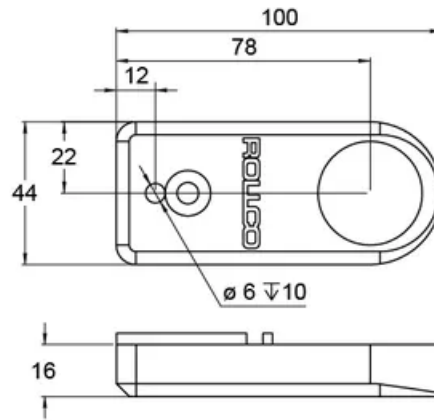

| Gear ratio (I) | Speed (m/min) |
|----------------|---------------|
| 5 | 37 (37,3) |
| 7,5 | 25 (24,9) |
| 10 | 19 (18,7) |
| 15 | 12 (12,4) |
| 20 | 9 (9,4) |
| 25 | 8 (7,5) |
| 30 | 6 (6,2) |
| 40 | 5 (4,7) |
| 50 | 4 (3,7) |

General Data

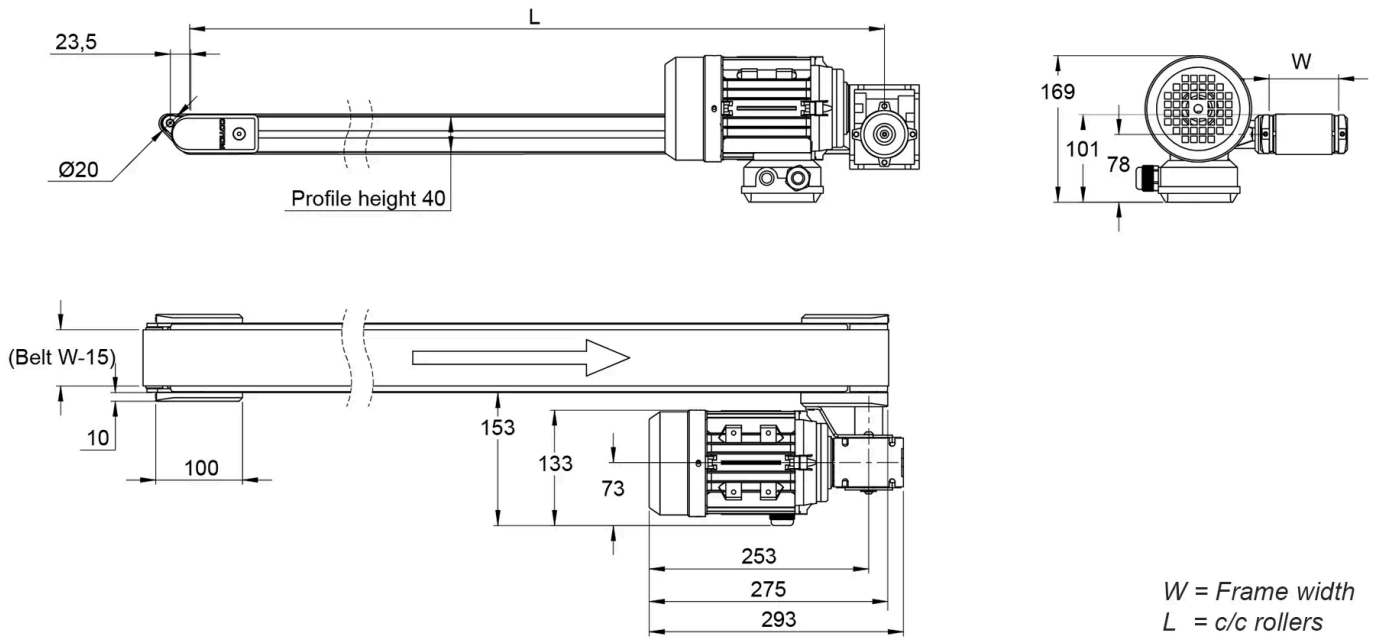

| Designation | Width (mm) |
|---------------|------------|
| BF40EIK - 40 | 40 |
| BF40EIK - 80 | 80 |
| BF40EIK - 120 | 120 |
| BF40EIK - 160 | 160 |
| BF40EIK - 200 | 200 |
| BF40EIK - 250 | 250 |
| BF40EIK - 300 | 300 |
| BF40EIK - 350 | 350 |
| BF40EIK - 400 | 400 |