

220 (Left) & 230 (Right) Lock in / Lock out - 100% Extension

The 220 (LH) & 230 (RH) are a pair of precision ball bearing slides with a complete integrated locking system. Automatically locked when the slide is fully extended and when fully closed. Slide smoothly and easily due to a row of ball bearings held in a nylon cage in each track. All aluminium slide. Carrying loads up to 90 kg per pair. Standard lengths 300 to 600 mm in 50 mm increments.



All dimensions in mm.

System Load Capacity value refers to a pair of rails.

Note 1: 15 mm dia. holes in centre allow easy access to fixing holes. M5 countersunk head screws to BS4183 are recommended for fixing.

Note 2: Elongated holes should be provided in either the framework or chassis to give adjustment if it is necessary for the panel to fit tight against the framework.

Material: Aluminium with steel ball bearings, standard anodizing finish silver.

Extension: 100%

General Data

220 (Left)

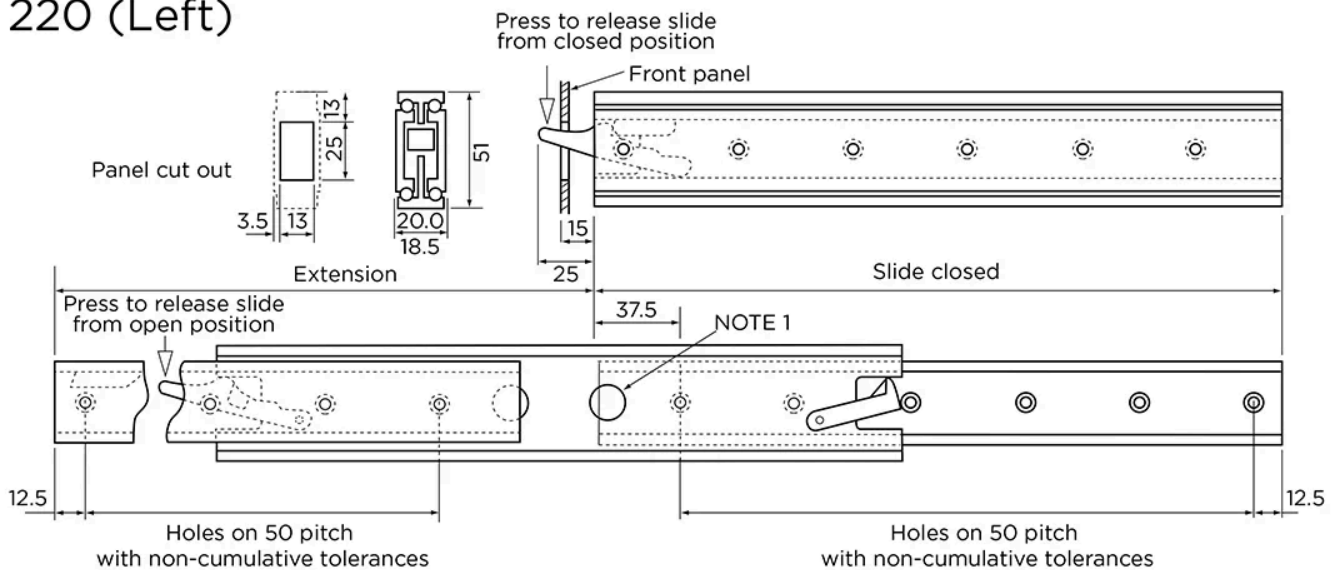

Note 1: 15 mm dia. holes in centre allow easy access to fixing holes. M5 countersunk head screws to BS4183 are recommended for fixing.

Note 2: Elongated holes should be provided in either the framework or chassis to give adjustment if it is necessary for the panel to fit tight against the framework.

230 (Right)

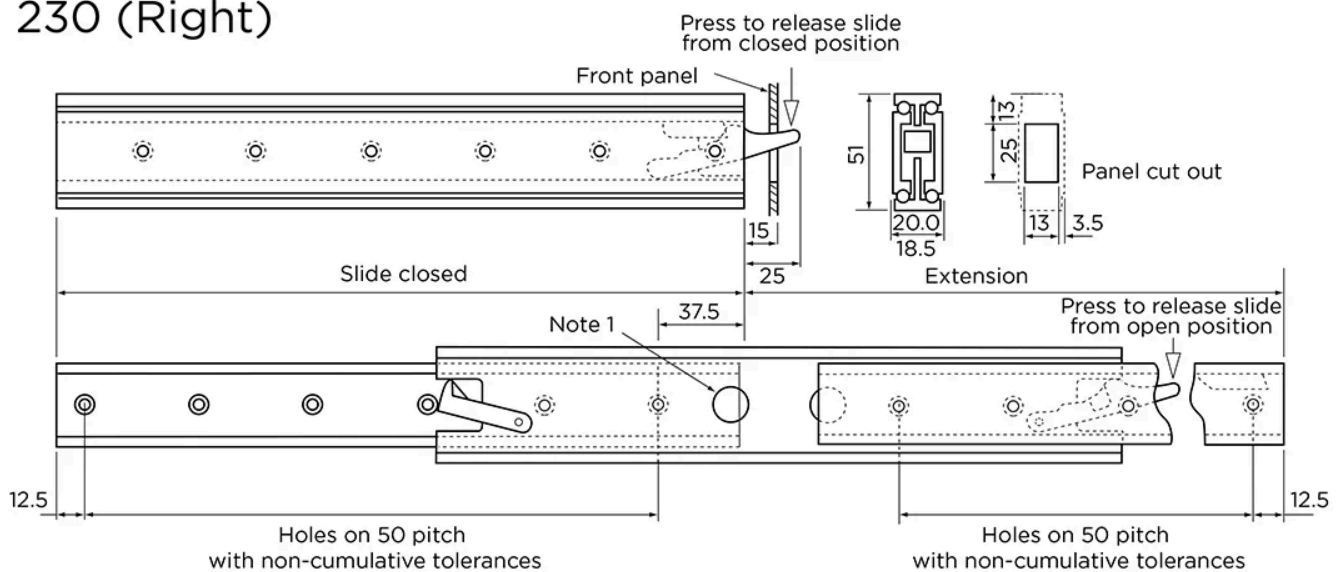

Note 1: 15 mm dia. holes in centre allow easy access to fixing holes. M5 countersunk head screws to BS4183 are recommended for fixing.

Note 2: Elongated holes should be provided in either the framework or chassis to give adjustment if it is necessary for the panel to fit tight against the framework.

Designation	Closed Length	Extension Length	System Load Capacity (N)	Number of Fixing Holes	Remark
220-300	300	330	550	6	Left
220-350	350	380	620	7	Left
220-400	400	430	710	8	Left
220-450	450	480	780	9	Left
220-500	500	530	840	10	Left
220-550	550	580	880	11	Left

Designation	Closed Length	Extension Length	System Load Capacity (N)	Number of Fixing Holes	Remark
220-600	600	630	900	12	Left
230-300	300	330	550	6	Right
230-350	350	380	620	7	Right
230-400	400	430	710	8	Right
230-450	450	480	780	9	Right
230-500	500	530	840	10	Right
230-550	550	580	880	11	Right
230-600	600	630	900	12	Right

Designation	Weight/pc (kg)
220-300	0.52
220-350	0.60
220-400	0.68
220-450	0.74
220-500	0.83
220-550	0.90
220-600	0.98
230-300	0.52
230-350	0.60
230-400	0.68
230-450	0.74
230-500	0.83
230-550	0.90
230-600	0.98