

## PSW 30 - Shaft 14 mm hollow

- Positioning system with IP 68
- Absolute measuring system, without battery
- Galvanically separated supply voltages between control and motor and bus
- Absolute encoder eliminates the need for reference runs during system setup and installation of replacements
- Easy address assignment directly on the device using integrated address switches (not for IO-Link)
- Manual disconnecting lever permits manual disconnection of the gearbox
- Regulation of the current torque prevents overloading and unnecessary run aborts
- Strong breakaway torque enables safe start-up even after an extended standstill
- Intelligent running behaviour. Recognises the difference between obstacles and dirt
- Spindle offset run: Excludes inconsistencies due to lash in the spindle
- Condition monitoring of supply voltage, drag error (permits optimum adjustment of current position), power consumption and torque
- Partial safety function for STO (Safe Torque Off)



Dimensions in mm.

**Type:** Horizontal

**Nominal Torque (Nm):** 1; 2; 5

**Nominal Speed (rpm):** 35; 90; 180

**Nominal Voltage (V DC):** 24 (± 10 %)

**Nominal Current (A):** 2.4

**Output Shaft (mm):** 14

**Output Shaft Type:** Hollow

**BUS Communication:** Can Open (CA); Profi Bus (DP); Device Net (DN); Modbus (MB); IO-Link (IO); ProfiNet (PN); Sercos (SE); EtherCat (EC); Ethernet IP (EI); PowerLink (PL)

**Electrical connection:** "Standard; with jog keys; 1 connector Y-encoded or 1 connector Y-encoded with jog keys"

**Protection Class:** IP68

**Motor:** EC-motor

**Supply Voltage:** 24 V DC ± 10 % galvanically separated between control and motor and bus

**Measurement System:** Absolute, optical-magnetic

**Accuracy:** ± 0.9°

**Intermittence:** 20% (basis time 600 s)

**Manual Adjustment:** Standard

**Brake:** Optional (holding brake)

**Material:** All components in stainless steel. (Except for feather key, if available.)

Performance Curve - Direct Drives PSW

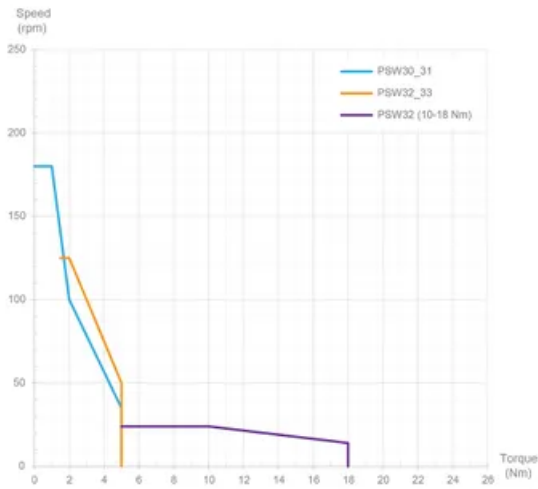

**General Data**

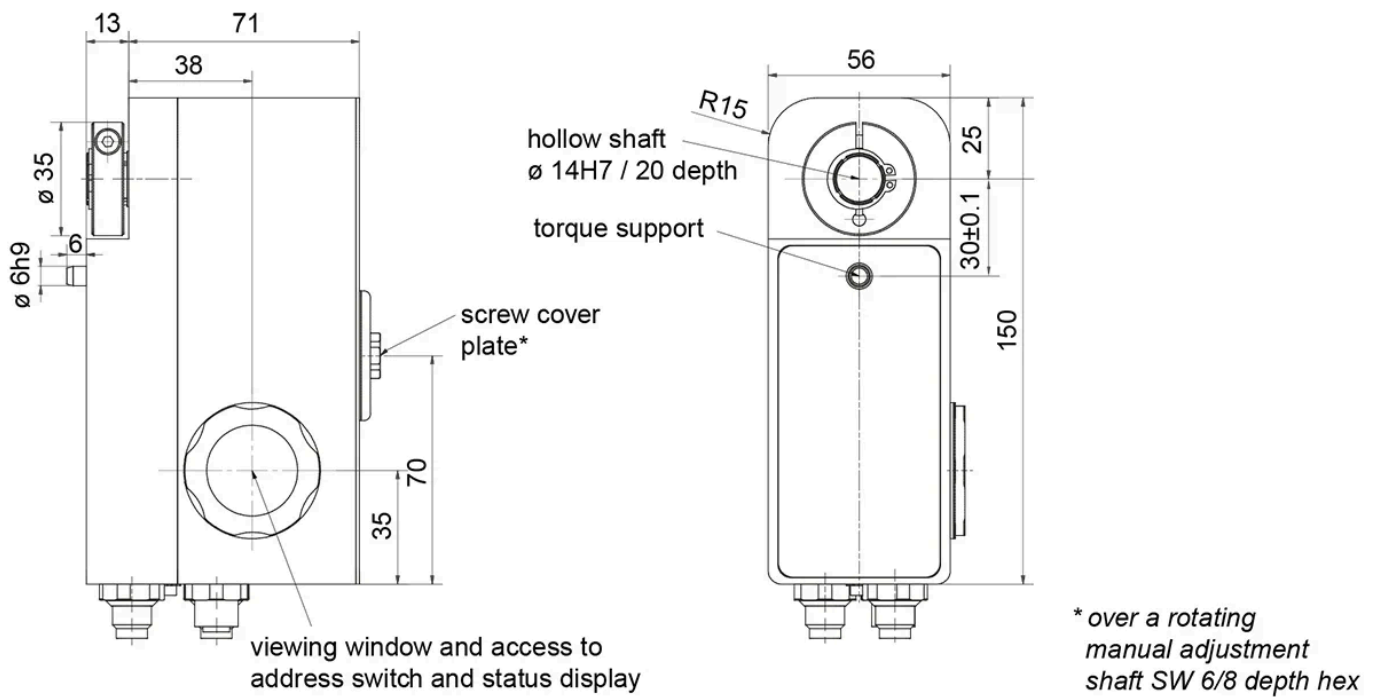

Designation	Nominal Torque (Nm)	Nominal Speed (rpm)	Nominal Current (A)	Self-holding Torque (Nm)	Positioning Range (rot.)
PSW 301-14H	1	180	2.4	0.5	250
PSW 302-14H	2	90	2.4	1	250
PSW 305-14H	5	35	2.4	2.5	250