

PSE 33 - Shaft 14 mm hollow

- Absolute measuring system
- Position control for direct connection to a control module
- Space-saving, compact design
- Galvanically separated supply voltages between control and motor and bus
- Durable EC-motor
- Extremely accurate positioning due to measurement of the position at the output side
- Bus interfaces simplify start-up and wiring complexity
- Address may be set using the bus or an address switch (not for IO-Link)
- Baud rate set via switch
- Status messages retrievable via bus
- Partial safety function for STO (Safe Torque Off)



Dimensions in mm.

Type: Vertical

Nominal Voltage (V DC): 24 (± 10 %)

Nominal Current (A): 3.1

Output Shaft (mm): 14

Output Shaft Type: Hollow

BUS Communication: Can Open (CA); Profi Bus (DP); Device Net (DN); Modbus (MB); IO-Link (IO); ProfiNet (PN); Sercos (SE); EtherCat (EC); Ethernet IP (EI); PowerLink (PL)

Electrical connection: "Standard; with jog keys; 1 connector Y-encoded or 1 connector Y-encoded with jog keys"

Protection Class: IP54; IP65

Motor: EC-motor

Supply Voltage: 24 V DC ± 10 % galvanically separated between control and motor and bus

Measurement System: Absolute, optical-magnetic

Accuracy: ± 0.9°

Intermittence: 25% (basis time 300 s)

Manual Adjustment: Standard

Brake: Optional (holding brake)

Performance Curve - Direct Drives PSE

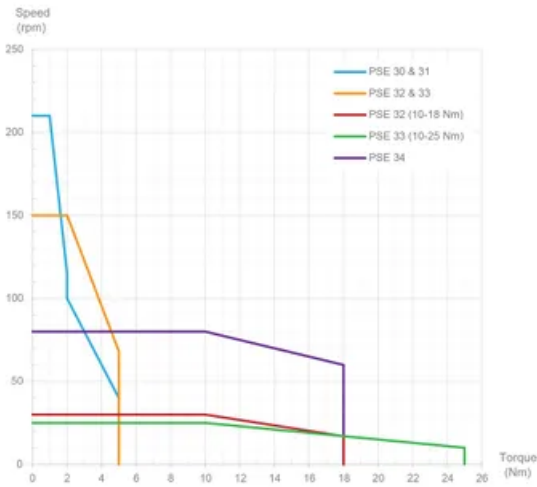

General Data

PSE 332 / 335-14

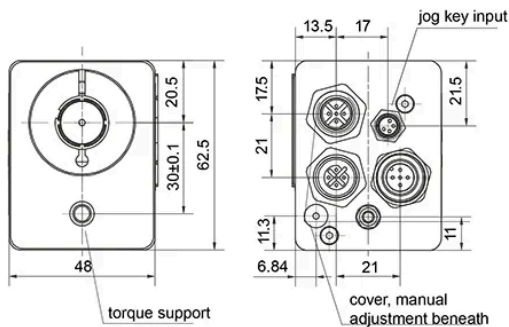
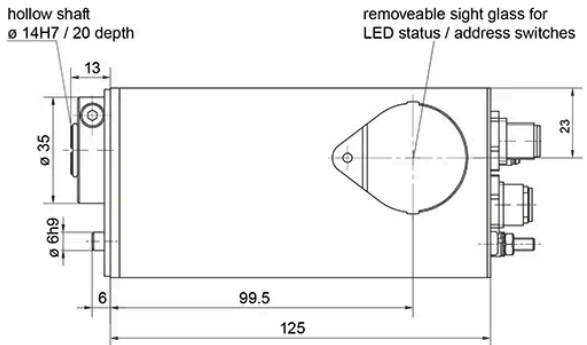

PSE 3310 / 3325-14

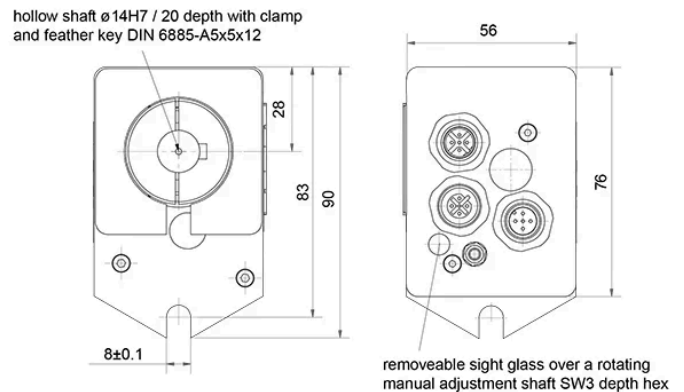
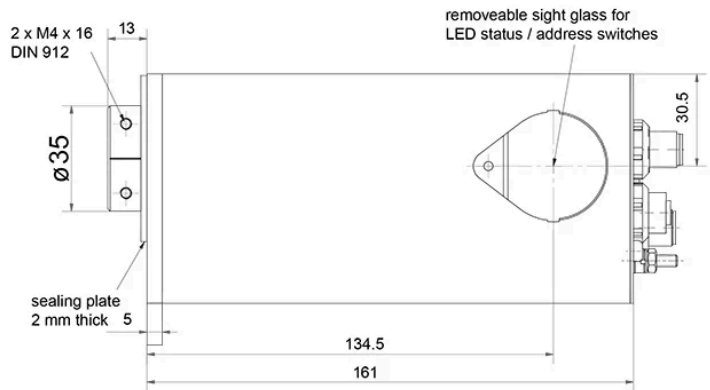

Designation	Nominal Torque (Nm)	Nominal Speed (rpm)	Nominal Current (A)	Self-holding Torque (Nm)	Positioning Range (rot.)
PSE 332-14	2	150	3.1	1	250
PSE 335-14	5	68	3.1	2.5	250
PSE 3310-14	10	25	3.1	5	250
PSE 3325-14	25	10	3.1	12.5	250