

## Linear Unit MTV 40

The MTV series describes linear units with precision ball screw drive, integrated guide rail and compact dimensions. The units use a precision ball screw, with tolerance class ISO7 (ISO5 on request), with reduced backlash of the ball nut. A corrosion-resistant protection strip, protects all the parts in the profile from dust and other contaminants.

To achieve higher speeds at the same stroke of the linear unit, the ball screw support system can be integrated. With this feature vibrations and deflections of the ball screw are reduced, therefore longer strokes are possible. The linear unit with integrated support system can have a higher axial load capacity. Ball screw supports are made of high quality plastic materials with high wear resistance properties. The system enables ball screw support in horizontal or vertical positioning of the linear unit.

A 2LR version of MTV linear unit is available, where two carriages are moving simultaneously in opposite directions. Both right- and left-handed precision ball screws are used, which are rigidly connected. The ball screw support system can also be integrated.

Dimensions in mm.

**Modulus of Elasticity:**  $E = 70000 \text{ N / mm}^2$

**Operating Temperature (°C):** 0 ~ +60 For operating temperature out of the presented range, please contact Rollco.

**Duty Cycle:** 100%

**Max. Acceleration (m/s<sup>2</sup>):** 20



# Linear Unit MTV 40

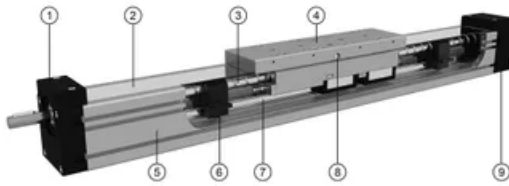

1. Drive block with floating bearing (MTV 110 - fixed bearing)
2. Corrosion-resistant protection strip
3. Ball screw tolerance ISO7 (ISO5 available on request)
4. Carriage with built in magnets
5. Aluminium profile - hard anodized
6. Screw support - SA
7. Integrated linear ball guideway
8. Central lubrication port, both sides
9. End block with fixed bearing (MTV 110 - floating bearing)

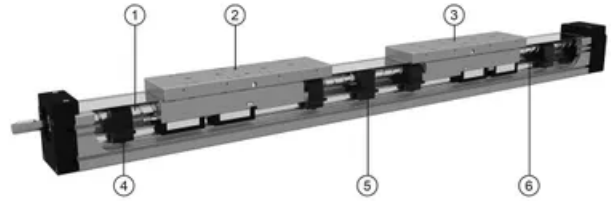

1. Right hand ball screw
2. Carriage with built in right hand ball nut
3. Carriage with built in left hand ball nut
4. Screw support - SA
5. Central screw support - fixed
6. Left hand ball screw

## Deflection of the linear unit (standard)

Fixed - fixed mounting

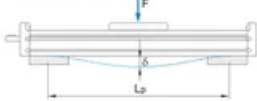

- delta: Maximum deflection of the linear unit [mm]
- delta\_max: Maximum permissible deflection of the linear unit [mm]
- F: Applied force [N]
- Lp: Unsupported profile length [mm]

Fixed - free mounting

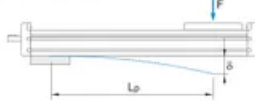

The maximum permissible deflection (delta\_max) must not be exceeded. In the case that maximum deflection (delta) exceeds the maximum permissible deflection (delta\_max) additional profile supports are needed.

## Deflection of the 2LR version

Fixed - fixed mounting

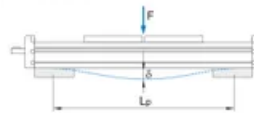

- delta: Maximum deflection of the linear unit [mm]
- delta\_max: Maximum permissible deflection of the linear unit [mm]
- F: Applied force [N]
- Lp: Unsupported profile length [mm]

The maximum permissible deflection (delta\_max) must not be exceeded. In the case that maximum deflection (delta) exceeds the maximum permissible deflection (delta\_max) additional profile supports are needed.

## Deflection of the linear unit

MTV 40

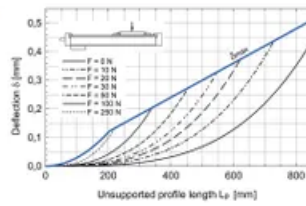
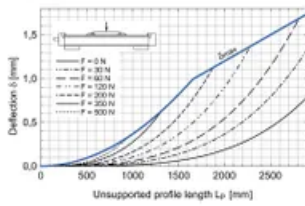

- ① The linear units do not include any safety stroke.
- Absolut stroke = Effective stroke + 2 x safety stroke.

SA	Lp
S	43.0
2SA	23.0
4SA	40.0
Lp	Maximum length [mm]

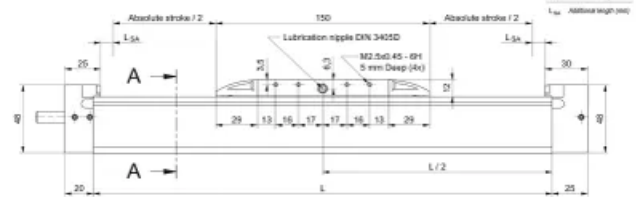

- ① Journal with or without keyway.
- ② All dimensions in mm. Drawings scale are not equal!

# Linear Unit MTV 40

① The linear units do not include any safety stroke  
 Absolute stroke = Effective stroke + 2 x safety stroke

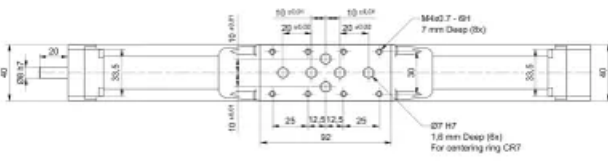

② Journal with or without keyway    ③ All dimensions in mm. Drawings scales are not equal!

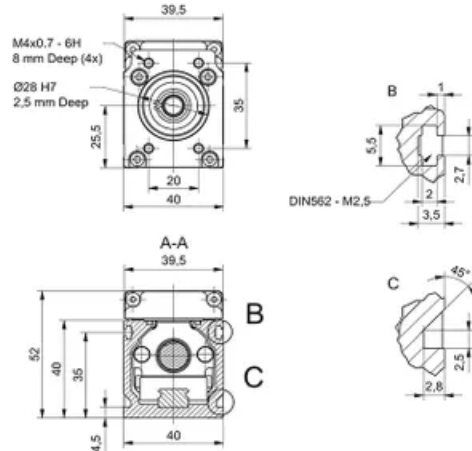

④ All dimensions in mm. Drawings scales are not equal.

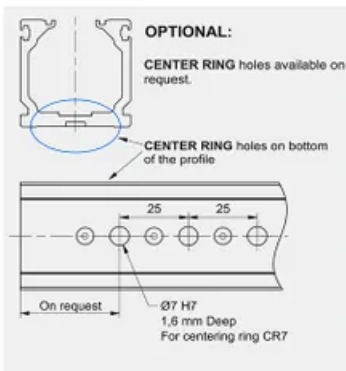

### Mounting the drive

- by the MOTOR SIDE DRIVE - MSD
- by the MOTOR ADAPTER WITH COUPLING

### Defining of the linear unit length

#### Standard version

$L = \text{Effective stroke} + 2 \times \text{Safety stroke} = L_e + 2 \times L_{sa} = A \times (n_c - 1) + 18 \text{ mm}$   
 Label =  $L_e + 45 \text{ mm}$ ,  $L_{sa} = 150 \text{ mm}$

Left side (L)

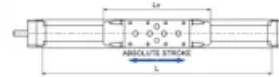

Right side (R)

#### Multiple carriages

$n_c$  - Number of carriages  
 A, 2, L, L<sub>e</sub> - Dimension between the carriages  
 Must be provided by the customer



## Linear Unit MTV 40

Maximum travel speed as a function of the profile length (vmax - L curves)

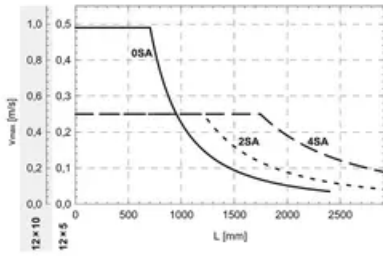

## General Data

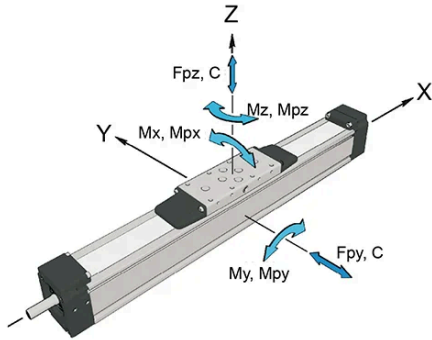

For lengths/stroke over the stated value please contact us. Values for max. stroke are not valid for multiple carriages and screw support SA (equation of defining the linear unit length for particular size of the linear unit need to be used).

### Recommended values of loads

All the data of dynamic moments and load capacities are theoretical without considering any safety factor. The safety factor depends on the application and its requested safety. We recommend a minimum safety factor ( $f_s = 5.0$ ).

Designation	Carriage Length $L_v$ (mm)	Dynamic Load Capacity C (N)	Dynamic Moment $M_x$ (Nm)	Dynamic Moment $M_y$ (Nm)	Dynamic Moment $M_z$ (Nm)
MTV 40 - 12 x 5	150	4620	28	260	260
MTV 40 - 12 x 10	150	4620	28	260	260

Designation	Max. Permissible Loads Forces $F_{py}$ (N)	Max. Permissible Loads Forces $F_{pz}$ (N)	Max. Permissible Loads Moments $M_{py}$ (Nm)	Max. Permissible Loads Moments $M_{pz}$ (Nm)	Max. Length $L_{max}$ (mm)	Max. Stroke (mm)
MTV 40 - 12 x 5	2300	3850	210	130	2900	2728
MTV 40 - 12 x 10	2300	3850	210	130	2900	2728

Designation	Min. Stroke (mm)
MTV 40 - 12 x 5	30
MTV 40 - 12 x 10	30

## Drive Data

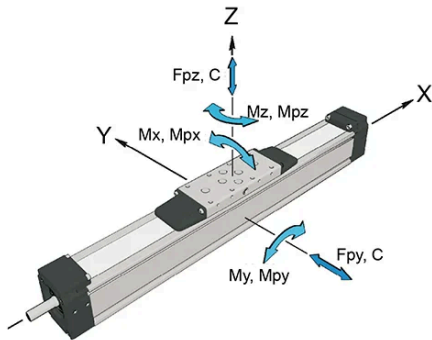

- Max. travel speed depends of the length of the linear unit, see diagram for particular size of the linear unit. For travel speed and acceleration over the stated value, please contact Rollco.
- For the ball nut with the preload of 2%, please contact Rollco.
- For minimum stroke below the stated value, please contact Rollco.

Designation	Max. Rotational Speed (without SA) (rev/min)	Max. Travel Speed (without SA) (m/s)	Lead Constant (mm/rev)	Ball Screw (d x l)	Max. Repeatability Precision Standard ISO7
MTV 40 - 12 x 5	5800	0.49	5	12 x 5	±0.02
MTV 40 - 12 x 10	5800	0.97	10	12 x 10	±0.02

Designation	Max. Repeatability Precision ISO5	Dynamic Load Capacity BS Ca (N)	Max. Axial Load Fx (N)	Max. Drive Torque Ma (Nm)	Planar Moment of Inertia Iy (cm <sup>4</sup> )	Planar Moment of Inertia Iz (cm <sup>4</sup> )
MTV 40 - 12 x 5	±0.01	5000	3400	3	10	11
MTV 40 - 12 x 10	±0.01	3800	2540	4.5	10	11

Designation	Max. Acceleration (m/s)
MTV 40 - 12 x 5	20
MTV 40 - 12 x 10	20

## Mass and Mass Moment

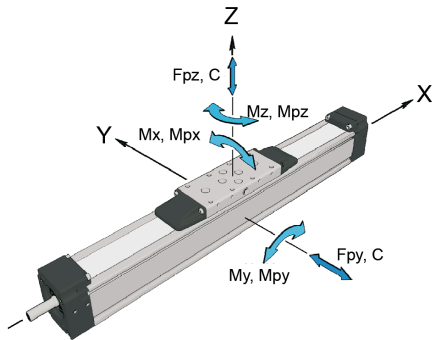

The stated values are for strokes (and for distances between carriages up to 500 mm.

No load torque value increases with stroke (and with A) elongation.

Mass calculation does not include mass of motor, reduction gear, switches and clamps.

Abs. stroke	Absolute stroke [mm]
A	Distance between carriages [mm]
nc	Number of carriages

Designation	Ball Screw (d x l)	Number of SA *SA	Mass of Linear Unit (kg)	Moved Mass (kg)	Mass Moment of Inertia (10 <sup>-5</sup> kg m <sup>2</sup> )
<b>MTV 40 - 12 x 5</b>	12 x 5	0 ; 2 ; 4	1.2 + 0.0028 × (Abs. Stroke + (nc - 1) × A) + 0.47 × (nc - 1) ; 1.3 + 0.0028 × (Abs. Stroke + (nc - 1) × A) + 0.47 × (nc - 1) ; 1.4 + 0.0028 × (Abs. Stroke + (nc - 1) × A) + 0.47 × (nc - 1)	0.47 + 0.47 × (nc - 1) ; 0.50 + 0.47 × (nc - 1) ; 0.53 + 0.47 × (nc - 1)	0.48 + 0.0012 × (Abs. Stroke + (nc - 1) × A) + 0.03 × (nc - 1) ; 0.53 + 0.0012 × (Abs. Stroke + (nc - 1) × A) + 0.03 × (nc - 1) ; 0.57 + 0.0012 × (Abs. Stroke + (nc - 1) × A) + 0.03 × (nc - 1)
<b>MTV 40 - 12 x 10</b>	12 x 10	0 ; 2 ; 4	1.2 + 0.0028 × (Abs. Stroke + (nc - 1) × A) + 0.47 × (nc - 1) ; 1.3 + 0.0028 × (Abs. Stroke + (nc - 1) × A) + 0.47 × (nc - 1) ; 1.4 + 0.0028 × (Abs. Stroke + (nc - 1) × A) + 0.47 × (nc - 1)	0.47 + 0.47 × (nc - 1) ; 0.50 + 0.47 × (nc - 1) ; 0.53 + 0.47 × (nc - 1)	0.57 + 0.0012 × (Abs. Stroke + (nc - 1) × A) + 0.12 × (nc - 1) ; 0.62 + 0.0012 × (Abs. Stroke + (nc - 1) × A) + 0.12 × (nc - 1) ; 0.67 + 0.0012 × (Abs. Stroke + (nc - 1) × A) + 0.12 × (nc - 1)

Designation	No Load Torque (Nm)	Planar Moment of Inertia Iy (cm <sup>4</sup> )	Planar Moment of Inertia Iz (cm <sup>4</sup> )
<b>MTV 40 - 12 x 5</b>	0.08 + 0.08 × (nc - 1) ; 0.09 + 0.08 × (nc - 1) ; 0.10 + 0.08 × (nc - 1)	10	11
<b>MTV 40 - 12 x 10</b>	0.09 + 0.09 × (nc - 1) ; 0.11 + 0.09 × (nc - 1) ; 0.14 + 0.09 × (nc - 1)	10	11