

## Couplings

The maximum transmittable torque of the clamping hub depends on the bore diameter.

For CAD-files contact Rollco.

Dimensions in mm.

Explanations to the table below:

Ms = Screw tightening torque (Nm)

W = Weight (Kg)

J = Coupling moment of inertia (kgm<sup>2</sup>)

nmax = Maximum rpm (min<sup>-1</sup>)

TKN = Coupling nominal torque (Nm)

Tkmax = Coupling maximum torque (Nm)

**Operating Temperature (°C): -30 and +90**



Recommended coupling bore diam. and transmissible torque (Nm)  
 - valid for shaft tolerances k6 without keyway

Size	Ø4	Ø5	Ø6	Ø7	Ø8	Ø9	Ø10	Ø11	Ø12	Ø14	Ø15	Ø16	Ø18	Ø20	Ø22	Ø24	Ø25	Ø28	Ø30	Ø32	Ø35	Ø38	Ø40	Ø42	Ø45
7	0.7	0.8	1	1.1																					
9	1.1	1.4	1.7	1.9	2.2	2.6	2.8																		
14		2.5	2.9	3.3	3.7	4.1	4.6	5	5.8	6.2	6.6														
19/24			23	25	27	32	34	36	43	45															
24/28				23	25	27	32	34	36	43	45	50	54	57	63										
28/38							58	62	66	79	83	91	100	104	116	124	133	145							
38/45											79	83	91	100	104	116	124	133	145	158	166	174	187		

## General Data

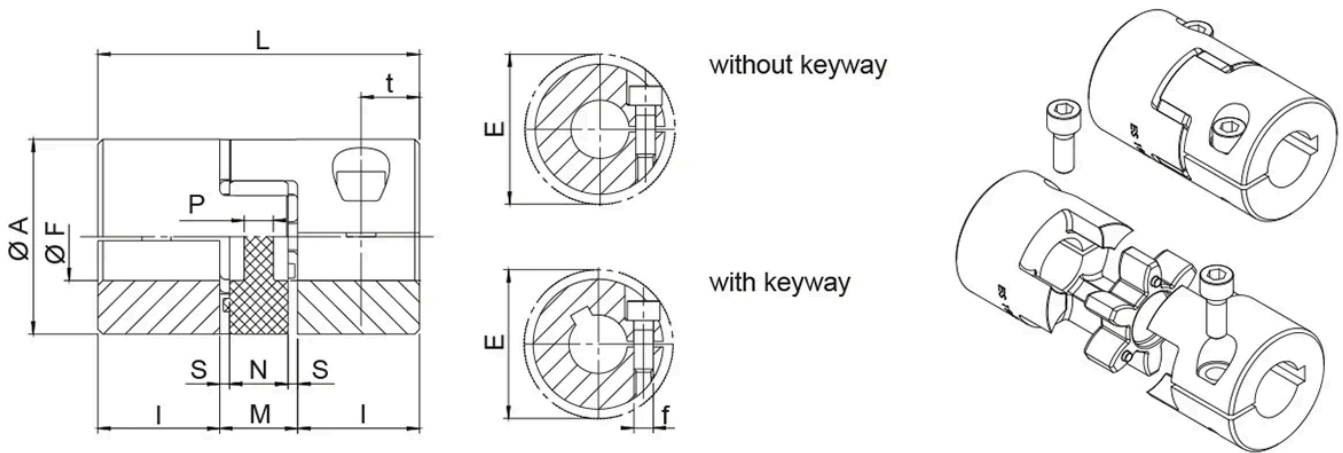

\* The values of nominal TKN and max. TKmax transmissible torque in the upper table are valid for coupling with keyway.

Designation	A	E	F(min)	F (max)	f
GESM7	14	15	3	7	M2
GESM9	20	23.4	4	10	M2,5
GESM14	30	32.2	6	16	M3
GESM19/24	40	45.7	10	20	M6
GESM24/28	55	56.4	10	32	M6
GESM28/38	65	72.6	14	35	M8
GESM38/45	80	83.3	19	45	M8

Designation	I	L	M	N	P	S
GESM7	7	22	8	6	6	1
GESM9	10	30	10	8	2	1
GESM14	11	35	13	10	2	1.5
GESM19/24	25	66	16	12	3.5	2
GESM24/28	30	78	18	14	4	2
GESM28/38	35	90	20	15	5.2	2.5
GESM38/45	45	114	24	18	5.6	3

Designation	t	TKN Nominal (Nm)	TKmax (Nm)	Ms (Nm)	Hub W (kg)	Hub J
GESM7	4	2	4	0.35	0.003	0.085 × 10 <sup>-6</sup> kgm <sup>2</sup>
GESM9	5	5	10	0.75	0.007	0.42 × 10 <sup>-6</sup> kgm <sup>2</sup>
GESM14	5.5	12.5	25	1.4	0.018	2.6 × 10 <sup>-6</sup> kgm <sup>2</sup>
GESM19/24	12	17	34	11	0.071	18.1 × 10 <sup>-6</sup> kgm <sup>2</sup>
GESM24/28	12	60	120	11	0.156	74.9 × 10 <sup>-6</sup> kgm <sup>2</sup>

Designation	t	TKN Nominal (Nm)	TKmax (Nm)	Ms (Nm)	Hub W (kg)	Hub J
<b>GESM28/38</b>	13.5	160	320	25	0.24	163.9 × 10 <sup>-6</sup> kgm <sup>2</sup>
<b>GESM38/45</b>	16	325	650	25	0.44	465.5 × 10 <sup>-6</sup> kgm <sup>2</sup>

Designation	nmax	Permissible bore diameters
<b>GESM7</b>	40.000 min <sup>-1</sup>	4 / 5 / 6 / 7
<b>GESM9</b>	28.000 min <sup>-1</sup>	5 / 5 / 6 / 7 / 8 / 9 / 10
<b>GESM14</b>	19.000 min <sup>-1</sup>	6 / 7 / 8 / 9 / 10 / 11 / 12 / 14 / 15 / 16
<b>GESM19/24</b>	14.000 min <sup>-1</sup>	10 / 11 / 12 / 14 / 15 / 16 / 19 / 20
<b>GESM24/28</b>	10.600 min <sup>-1</sup>	10 / 11 / 12 / 14 / 15 / 16 / 19 / 20 / 22 / 24 / 25 / 28
<b>GESM28/38</b>	8.500 min <sup>-1</sup>	14 / 15 / 16 / 19 / 20 / 22 / 24 / 25 / 28 / 30 / 32 / 35
<b>GESM38/45</b>	7.100 min <sup>-1</sup>	19 / 20 / 22 / 24 / 25 / 28 / 30 / 32 / 35 / 38 / 40 / 42 / 45