

## Linear Unit QME-WIL

With handwheel locking and position indicator.

QME is a ready to mount positioning table guided with linear ball bearings on hardened shafts and driven by ball- or lead screw. QME can be manually driven by handwheel using either ball screw or lead screw. For drive by motor, the ball screw versions are strongly recommended for sustained performance and precision.



Rollco recommend locking device for all hand driven units with ball screw to avoid back driving. Locking device is always included if position indicator is selected.

The position indicator has 4 digits where the three black-background digits represent position in millimetre and the red-backgrounds digit 1/10 of a millimetre.

Customized machining of the drive- and mounting interfaces, higher level of corrosion resistance or low/high temperature versions, please contact Rollco.

Bellow for Linear Unit QME is recommended for all applications where the unit isn't protected against dust and dirt. The bellow may also work as a pinch protection.

All dimensions in mm.

QME12-WIL: Max. L tot: 1 000 mm

QME20-WIL: Max. L tot: 1 500 mm

QME30-WIL: Max. L tot: 2 000 mm

## Linear Unit QME-WIL

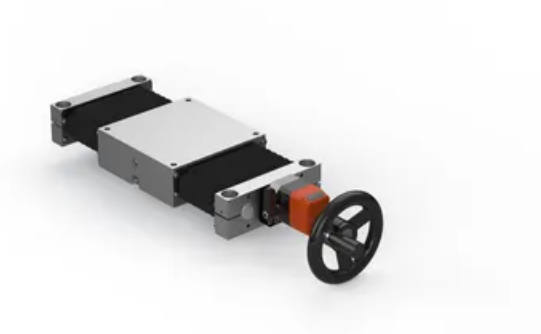

## General Data

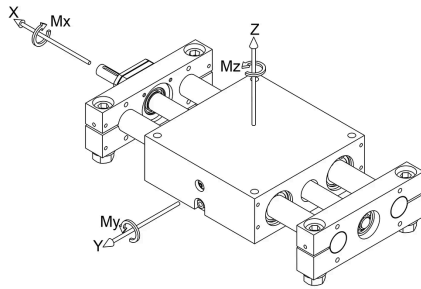

### Permissible load Fz and Fy

Permissible load based on a shaft deflection of 1/1000 of Ltot. For long units, actual load may need to be reduced to achieve a deflection acceptable for the application.

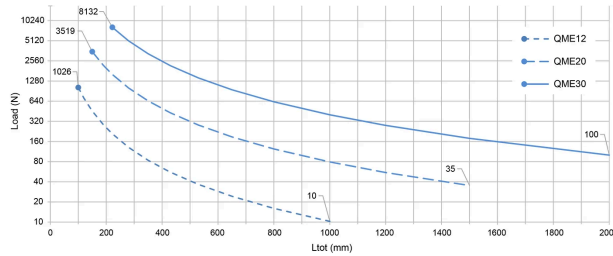

All capacity values are based on the individual ratings of the linear ball bearings used inside the QME and are without any safety factor. The usable load level depends on required service life and the system configuration. The safety factor depends on the application and its requested safety. We recommend a minimum dynamic safety factor 5.

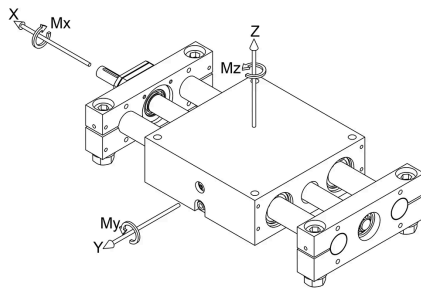

### Permissible load Fx

Permissible load is based on the buckling limit of the drive screw. For QME30, buckling will never occur due to the use of oversized drive screws.

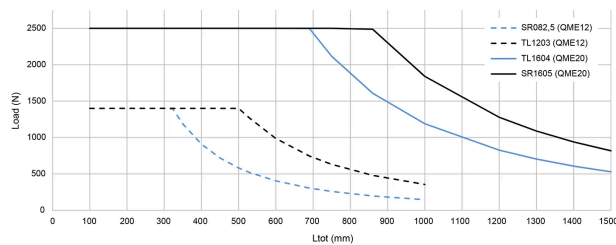

All capacity values are based on the individual ratings of the linear ball bearings used inside the QME and are without any safety factor. The usable load level depends on required service life and the system configuration. The safety factor depends on the application and its requested safety. We recommend a minimum dynamic safety factor 5.

| Designation | Screw Type                             | Static Load Capacity Fz (N) | Dynamic Load Capacity Fz (N) | Static Load Capacity Fy (N) | Dynamic Load Capacity Fy (N) |
|-------------|--|-----------------------------|------------------------------|-----------------------------|------------------------------|
| QME12-WIL   | SR082,5, TR1203, TL1203                | 3160                        | 2080                         | 3160                        | 2080                         |
| QME20-WIL   | SR1605, TR1604, TL1604                 | 5600                        | 3520                         | 5600                        | 3520                         |
| QME30-WIL   | SR3205, SL3205, SR3210, SR3220, TR3006 | 11200                       | 6400                         | 11200                       | 6400                         |

| Designation | Static Load Capacity Mx (Nm) | Dynamic Load Capacity Mx (Nm) | Static Load Capacity My (Nm) | Dynamic Load Capacity My (Nm) | Static Load Capacity Mz (Nm) | Dynamic Load Capacity Mz (Nm) |
|-------------|------------------------------|-------------------------------|------------------------------|-------------------------------|------------------------------|-------------------------------|
| QME12-WIL   | 71                           | 47                            | 74                           | 49                            | 74                           | 49                            |
| QME20-WIL   | 202                          | 127                           | 216                          | 136                           | 216                          | 136                           |
| QME30-WIL   | 728                          | 416                           | 678                          | 387                           | 678                          | 387                           |

| Designation | Dynamic Capacity Ca (N) | Permissible Fx (N) |
|-------------|-------------------------|--------------------|
| QME12-WIL   | 2030 (n/a for TR)       | 1400               |
| QME20-WIL   | 7100 (n/a for TR)       | 2500               |
| QME30-WIL   | 9500 (n/a for TR)       | 3200               |

# Dimensions

QME12-WIL

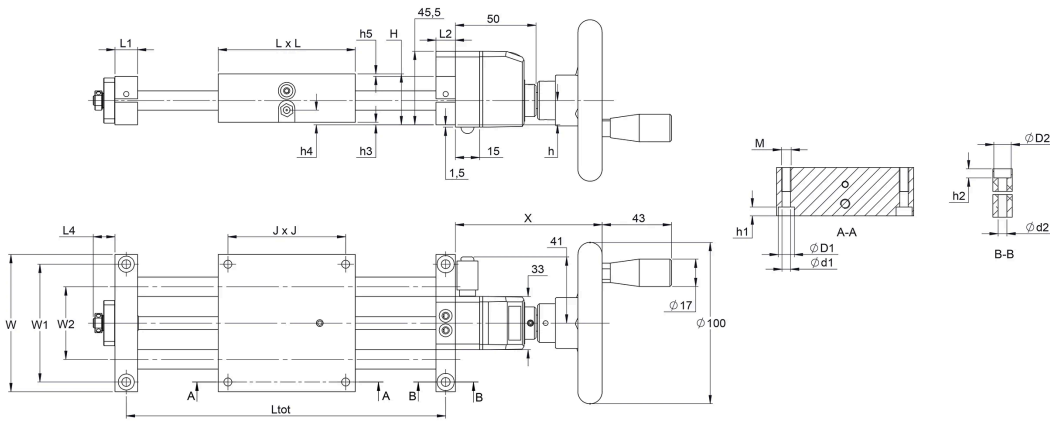

QME20-WIL

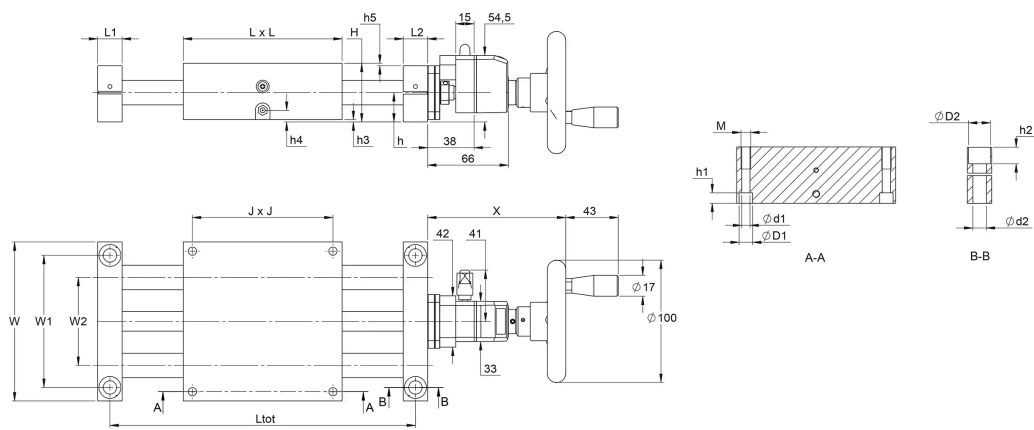

**QME30-WIL**

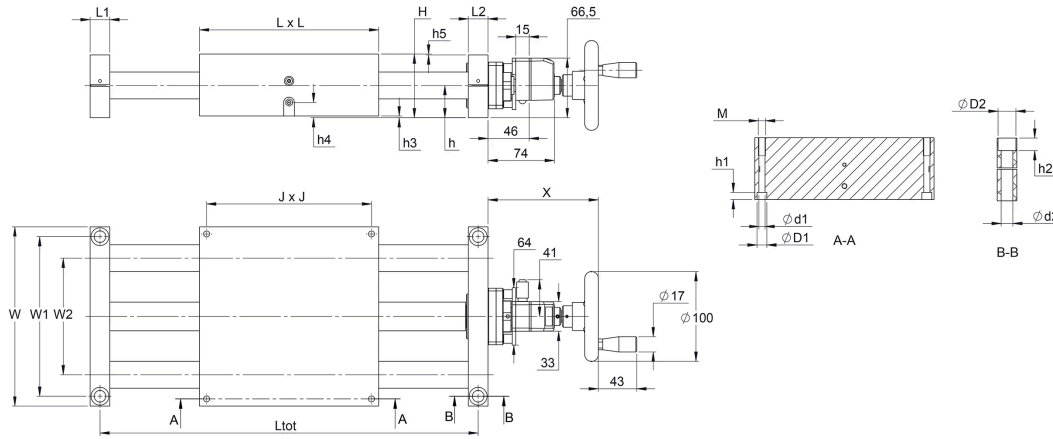

**Stroke definition**

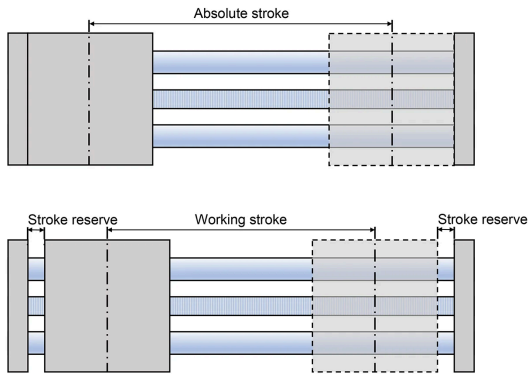

Working stroke: Is the working stroke of the application.  
 Absolute stroke: Is defined as Working stroke + Stroke reserve.  
 Stroke reserve: Is a safety distance to the mechanical end positions.

|       | Max. Ltot | Max. absolute stroke |              |
|-------|-----------|----------------------|--------------|
|       |           | no bellows           | with bellows |
| QME12 | 1 000 mm  | 902 mm               | 693 mm       |
| QME20 | 1 500 mm  | 1 350 mm             | 1 084 mm     |
| QME30 | 2 000 mm  | 1 778 mm             | 1 493 mm     |

| Designation      | Ltot                 | Bellow Ltot               | D1 | d1  | D2 | d2  | H    | h  | h1  |
|------------------|----------------------|---------------------------|----|-----|----|-----|------|----|-----|
| <b>QME12-WIL</b> | Absolute stroke +98  | Absolute stroke *1.28+113 | 10 | 5.2 | 10 | 5.5 | 31.5 | 15 | 5.5 |
| <b>QME20-WIL</b> | Absolute stroke +150 | Absolute stroke *1.23+166 | 11 | 6.8 | 18 | 11  | 48   | 24 | 8   |
| <b>QME30-WIL</b> | Absolute stroke +222 | Absolute stroke *1.18+238 | 11 | 6.8 | 20 | 13  | 71   | 36 | 8   |

| Designation      | h2   | h3  | h4  | h5  | J   | L   | L1 | L2 | L4   | M       |
|------------------|------|-----|-----|-----|-----|-----|----|----|------|---------|
| <b>QME12-WIL</b> | 5.7  | 1.5 | 7.5 | 1.5 | 73  | 85  | 12 | 14 | 13.5 | M6 x 15 |
| <b>QME20-WIL</b> | 13.5 | 2   | 7.5 | 2   | 115 | 130 | 20 | 20 | -    | M8 x 18 |
| <b>QME30-WIL</b> | 14   | 2   | 15  | 1   | 184 | 200 | 22 | 22 | -    | M8 x 20 |

| Designation      | W   | W1  | W2  | X     |
|------------------|-----|-----|-----|-------|
| <b>QME12-WIL</b> | 85  | 73  | 45  | 91    |
| <b>QME20-WIL</b> | 130 | 108 | 72  | 113.5 |
| <b>QME30-WIL</b> | 200 | 178 | 130 | 123   |

## Weight

| Designation | Zero stroke (kg)         | Moving part (kg)         | +/100 mm stroke (kg)     | Remark   |
|-------------|--------------------------|--------------------------|--------------------------|--|
| QME12-WIL   | 1.02 / 1.04 with bellows | 0.55 / 0.57 with bellows | 0.22 / 0.28 with bellows | Masses may deviate +/- 5% depending on screw type and other options. |
| QME20-WIL   | 3.52 / 3.56 with bellows | 1.76 / 1.80 with bellows | 0.65 / 0.80 with bellows | Masses may deviate +/- 5% depending on screw type and other options. |
| QME30-WIL   | 12.3 / 12.4 with bellows | 5.77 / 5.91 with bellows | 1.73 / 2.04 with bellows | Masses may deviate +/- 5% depending on screw type and other options. |