

## WRB

Dimensions in mm.

Reduction of load rating for linear ball bearing because of less hardness.

Other types available on request.

**Material:** X46Cr13 / 1.4034

**Surface hardness:** 52 HRC min. Hardening depth according to DIN ISO 18203.

**Standard Tolerance:** ISO h6



## General Data

Designation	Weight (kg/m)
WRB5	0.15
WRB6	0.22
WRB8	0.39
WRB10	0.62
WRB12	0.89
WRB14	1.21
WRB16	1.58
WRB20	2.47
WRB25	3.85
WRB30	5.55
WRB40	9.86
WRB50	15.41
WRB60	22.2

## Dimensions

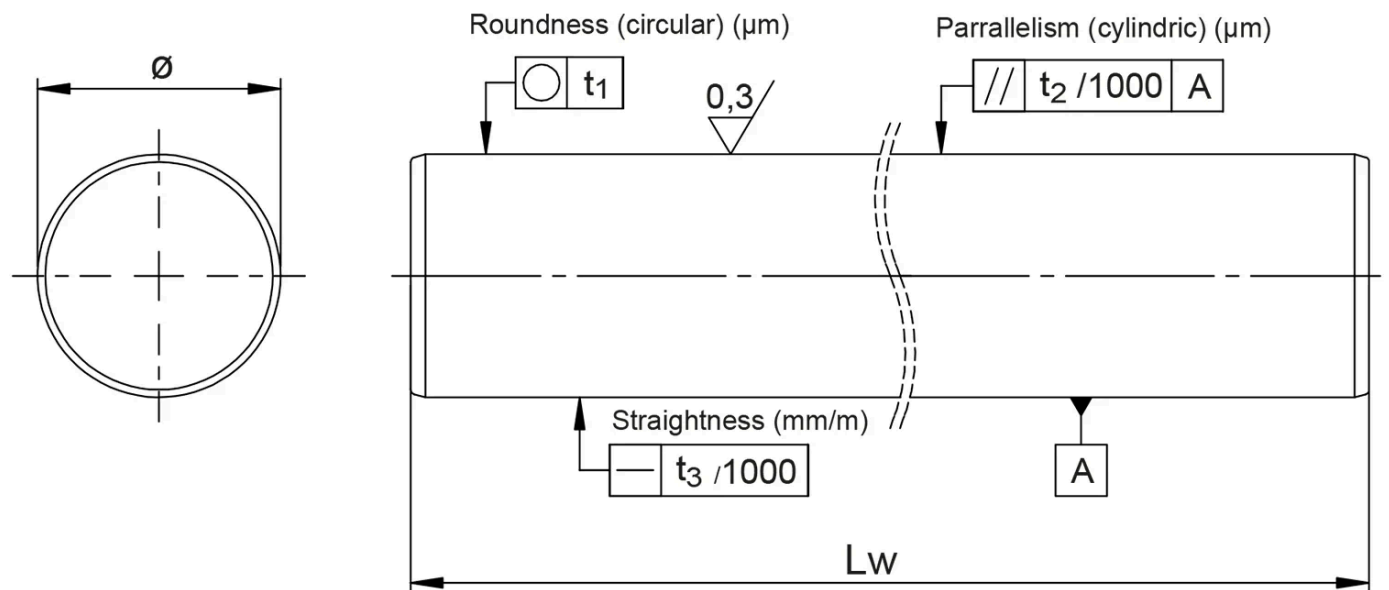

Designation	Lw (mm)	Diameter	Hardening Depth (mm)	Roundness t1 ( $\mu\text{m}$ )	Parallelism t2 ( $\mu\text{m}$ )	Straightness t3 (mm/m)
WRB5	3000	5	0.4	4	5	0.3
WRB6	6000	6	0.4	4	5	0.3
WRB8	6000	8	0.4	4	6	0.3
WRB10	6000	10	0.4	4	6	0.3
WRB12	6000	12	0.6	5	8	0.3
WRB14	6000	14	0.6	5	8	0.3
WRB16	6000	16	0.6	5	8	0.2
WRB20	6000	20	0.9	6	9	0.2
WRB25	6000	25	0.9	6	9	0.2
WRB30	6000	30	0.9	6	9	0.2

Designation	Lw (mm)	Diameter	Hardening Depth (mm)	Roundness t1 (µm)	Parallelism t2 (µm)	Straightness t3 (mm/m)
<b>WRB40</b>	6000	40	1.5	7	11	0.2
<b>WRB50</b>	6000	50	1.5	7	11	0.2
<b>WRB60</b>	6000	60	2.2	8	13	0.2