

Rollers for Plate Version

CONCENTRIC ROLLER

RSBLN: Standard bearing steel

RXBLN: Stainless bearing steel (AISI-440C)

ECCENTRIC ROLLER

RSBLA: Standard bearing steel

RXBLA: Stainless bearing steel (AISI-440C)

Standard slider is with 3 rollers. The rollers can also be mounted directly into your application or we can make special sliders according to your needs. Please contact Rollco for more information.



General Data

Designation	Weight (kg)
RSBLN20-2Z	0.006
RXBLN20-2RS	0.006
RSBLA20-2Z	0.006
RXBLA20-2RS	0.006
RSBLN30-2Z	0.02
RXBLN30-2RS	0.02
RSBLA30-2Z	0.02
RXBLA30-2RS	0.02
RSBLN45-2Z	0.068
RXBLN45-2RS	0.068
RSBLA45-2Z	0.068
RXBLA45-2RS	0.068

Dimensions

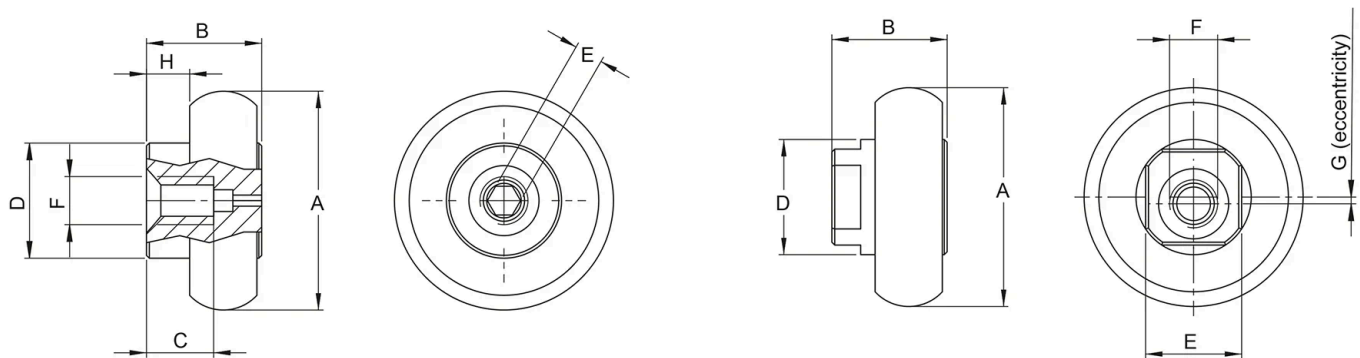

Designation	A	B	C	D	E	F	G	H
RSBLN20-2Z	14 +0/-0.04	8.2	6	8	2	M4	-	4
RXBLN20-2RS	14 +0/-0.04	8.2	6	8	2	M4	-	4
RSBLA20-2Z	14 +0/-0.04	8.2	6	8	6	M4	0.5	4
RXBLA20-2RS	14 +0/-0.04	8.2	6	8	6	M4	0.5	4
RSBLN30-2Z	22.8 +0/-0.05	12	7	12	3	M5	-	4.5
RXBLN30-2RS	22.8 +0/-0.05	12	7	12	3	M5	-	4.5
RSBLA30-2Z	22.8 +0/-0.05	12	7	12	10	M5	0.7	4.5
RXBLA30-2RS	22.8 +0/-0.05	12	7	12	10	M5	0.7	4.5
RSBLN45-2Z	35.6 +0/-0.06	17.3	12	16	3	M6	-	6
RXBLN45-2RS	35.6 +0/-0.06	17.3	12	16	3	M6	-	6
RSBLA45-2Z	35.6 +0/-0.06	17.3	12	16	13	M6	0.8	6
RXBLA45-2RS	35.6 +0/-0.06	17.3	12	16	13	M6	0.8	6