

## Rollers CPN-CPA

Available individually in all sizes as eccentric or concentric rollers. Prismatic roller for T- and U-rail.

Roller seals: Standard 2Z (2ZR for size 63) is the steel cover disc, which is supplied on all standard sliders.

For dusty environment and splash-proof applications, 2RS rubber seal rollers are available.

Rollers are lubricated for life



Dimensions in mm.

**Material:** Steel 100Cr6. Also available in stainless steel AISI 440.

## General Data

Designation	Size	Roller type	Material
CPN18-2RS	18	Concentric	Steel
CXPNX18-2RS	18	Concentric	Stainless steel
CPN18-2Z	18	Concentric	Steel
CPA18-2RS	18	Eccentric	Steel
CXPAX18-2RS	18	Eccentric	Stainless steel
CPA18-2Z	18	Eccentric	Steel
CPN28-2RS	28	Concentric	Steel
CXPNX28-2RS	28	Concentric	Stainless steel
CPN28-2Z	28	Concentric	Steel
CPA28-2RS	28	Eccentric	Steel
CXPAX28-2RS	28	Eccentric	Stainless steel
CPA28-2Z	28	Eccentric	Steel
CPN43-2RS	43	Concentric	Steel
CXPNX43-2RS	43	Concentric	Stainless steel
CPN43-2Z	43	Concentric	Steel
CPA43-2RS	43	Eccentric	Steel
CXPAX43-2RS	43	Eccentric	Stainless steel
CPA43-2Z	43	Eccentric	Steel
CPN63-2ZR	63	Concentric	Steel
CXPNX63-2RS	63	Concentric	Stainless steel
CPA63-2ZR	63	Eccentric	Steel
CXPAX63-2RS	63	Eccentric	Stainless steel

## Dimensions

### Version

### Prismatic (T- and U-rail)

CPN  
Concentric roller

CPA  
Eccentric roller

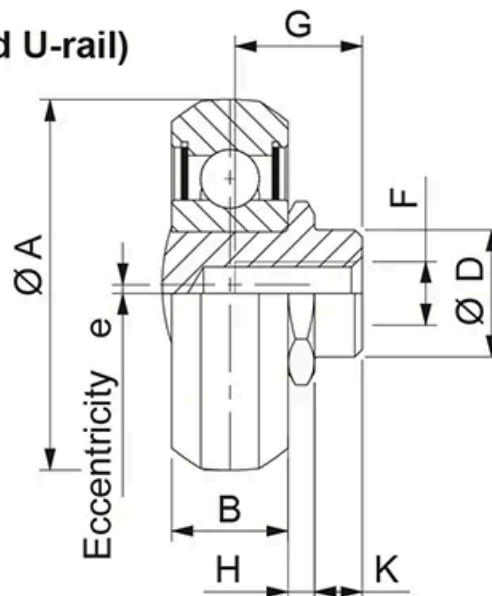

Designation	A	B	D	e	H	G	F	K
CPN18-2RS	14	4	6	-	1.55	5.5	M4	1.8

Designation	A	B	D	e	H	G	F	K
CXPNX18-2RS	14	4	6	-	1.55	5.5	M4	1.8
CPN18-2Z	14	4	6	-	1.55	5.5	M4	1.8
CPA18-2RS	14	4	6	0.4	1.55	5.5	M4	1.8
CXPAX18-2RS	14	4	6	0.4	1.55	5.5	M4	1.8
CPA18-2Z	14	4	6	0.4	1.55	5.5	M4	1.8
CPN28-2RS	23.2	7	10	-	2.2	7	M5	3.8
CXPNX28-2RS	23.2	7	10	-	2.2	7	M5	3.8
CPN28-2Z	23.2	7	10	-	2.2	7	M5	3.8
CPA28-2RS	23.2	7	10	0.6	2.2	7	M5	3.8
CXPAX28-2RS	23.2	7	10	0.6	2.2	7	M5	3.8
CPA28-2Z	23.2	7	10	0.6	2.2	7	M5	3.8
CPN43-2RS	35	11	12	-	2.5	12	M6	4.5
CXPNX43-2RS	35	11	12	-	2.5	12	M6	4.5
CPN43-2Z	35	11	12	-	2.5	12	M6	4.5
CPA43-2RS	35	11	12	0.8	2.5	12	M6	4.5
CXPAX43-2RS	35	11	12	0.8	2.5	12	M6	4.5
CPA43-2Z	35	11	12	0.8	2.5	12	M6	4.5
CPN63-2ZR	50	17.5	18	-	2.3	16	M8	6
CXPNX63-2RS	50	17.5	18	-	2.3	16	M8	6
CPA63-2ZR	50	17.5	18	1.2	2.3	16	M10	6
CXPAX63-2RS	50	17.5	18	1.2	2.3	16	M10	6

## Load & Weight

Designation	C (N)	C0rad (N)	Weight (kg)
CPN18-2RS	765	410	0.004
CXPNX18-2RS	765	410	0.004
CPN18-2Z	765	410	0.004
CPA18-2RS	765	410	0.004
CXPAX18-2RS	765	410	0.004
CPA18-2Z	765	410	0.004
CPN28-2RS	2130	1085	0.019
CXPNX28-2RS	2130	1085	0.019
CPN28-2Z	2130	1085	0.019
CPA28-2RS	2130	1085	0.019
CXPAX28-2RS	2130	1085	0.019
CPA28-2Z	2130	1085	0.019
CPN43-2RS	6140	2750	0.06
CXPNX43-2RS	6140	2750	0.06
CPN43-2Z	6140	2750	0.06
CPA43-2RS	6140	2750	0.06
CXPAX43-2RS	6140	2750	0.06
CPA43-2Z	6140	2750	0.06
CPN63-2ZR	15375	6250	0.19
CXPNX63-2RS	15375	6250	0.19

Designation	C (N)	C0rad (N)	Weight (kg)
CPA63-2ZR	15375	6250	0.19
CXPAX63-2RS	15375	6250	0.19

## Assembly Dimensions & Tolerances

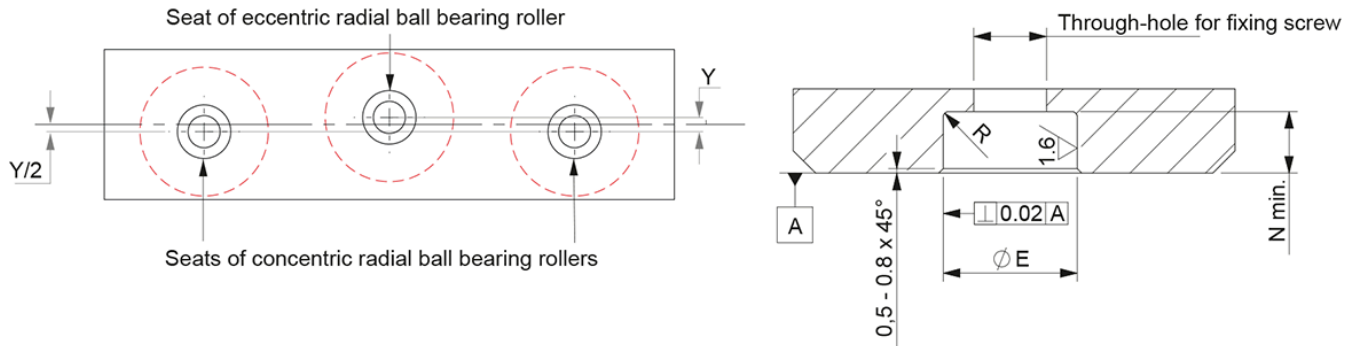

When installing Radial ball bearing rollers on your own structure we advise:

- Using a maximum of 2 concentric radial ball bearing rollers.
- Offset the seats of the concentric radial ball bearing rollers with respect to those of the eccentric radial ball bearing rollers according to the information below.

Designation	Y	E	N min.	Radius R
CPN18-2RS	0.30	6 + 0.025/+0.01	2.1	0.5
CXPNX18-2RS	0.30	6 + 0.025/+0.01	2.1	0.5
CPN18-2Z	0.30	6 + 0.025/+0.01	2.1	0.5
CPA18-2RS	0.30	6 + 0.025/+0.01	2.1	0.5
CXPAX18-2RS	0.30	6 + 0.025/+0.01	2.1	0.5
CPA18-2Z	0.30	6 + 0.025/+0.01	2.1	0.5
CPN28-2RS	0.64	10 + 0.03/+0.01	4.0	0.5
CXPNX28-2RS	0.64	10 + 0.03/+0.01	4.0	0.5
CPN28-2Z	0.64	10 + 0.03/+0.01	4.0	0.5
CPA28-2RS	0.64	10 + 0.03/+0.01	4.0	0.5
CXPAX28-2RS	0.64	10 + 0.03/+0.01	4.0	0.5
CPA28-2Z	0.64	10 + 0.03/+0.01	4.0	0.5
CPN43-2RS	0.72	12 + 0.05/+0.02	5.5	1
CXPNX43-2RS	0.72	12 + 0.05/+0.02	5.5	1
CPN43-2Z	0.72	12 + 0.05/+0.02	5.5	1
CPA43-2RS	0.72	12 + 0.05/+0.02	5.5	1
CXPAX43-2RS	0.72	12 + 0.05/+0.02	5.5	1
CPA43-2Z	0.72	12 + 0.05/+0.02	5.5	1
CPN63-2ZR	0.55	18 + 0.02/-0.02	7	1
CXPNX63-2RS	0.55	18 + 0.02/-0.02	7	1
CPA63-2ZR	0.55	18 + 0.02/-0.02	7	1
CXPAX63-2RS	0.55	18 + 0.02/-0.02	7	1