

## Slider Plate Version

LSWL: Stainless steel body (AISI 304) with wipers and standard steel rollers

LXWL: Stainless steel body (AISI 304) with wipers and stainless steel rollers (AISI-440C)



## General Data

Designation	Weight (kg)	Max. Permissible Radial Load Fmax (N)	Max. Permissible Axial Load Fmax (N)
LSWL20-80-2Z	0.05	300	170
LSWL30-88-2Z	0.11	800	400
LSWL45-150-2Z	0.40	1600	860
LXWL20-80-2RS	0.05	300	170
LXWL30-88-2RS	0.11	800	400
LXWL45-150-2RS	0.40	1600	860

## Dimensions

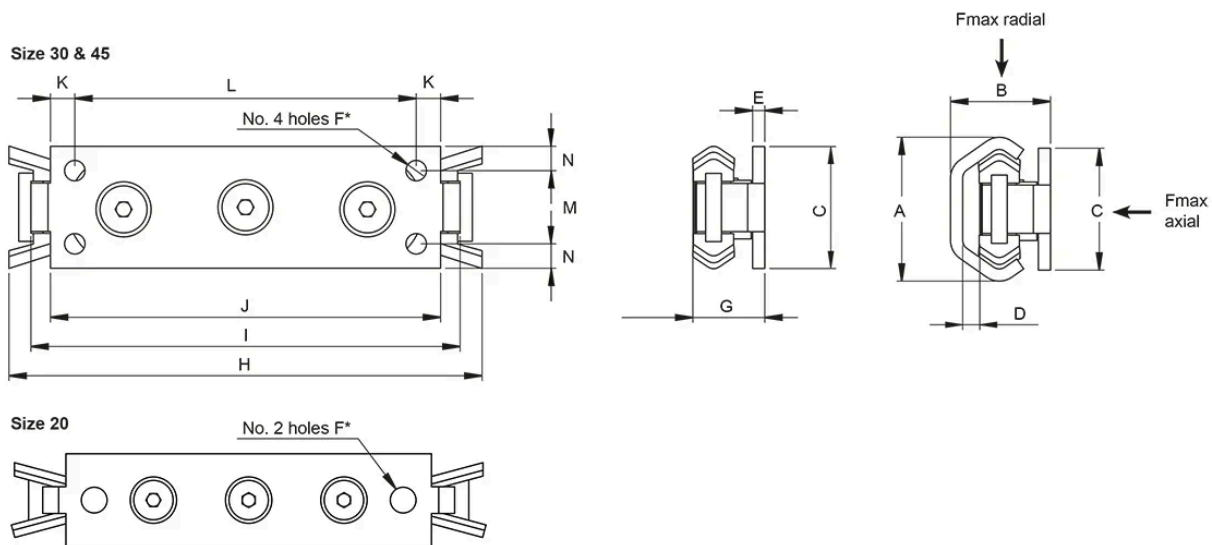

Designation	A	B	C	D	E	F	G	H	I
LSWL20-80-2Z	19.2	16	18	2.5	3	M5	11.5	91	80
LSWL30-88-2Z	29.5	20.5	25	3.5	2.5	M5	14.5	97	88
LSWL45-150-2Z	45.7	31.0	40	5.0	4.0	M6	22	160	150
LXWL20-80-2RS	19.2	16.0	18	2.5	3.0	M5	11.5	91	80
LXWL30-88-2RS	29.5	20.5	25	4.0	2.5	M5	14.5	97	88
LXWL45-150-2RS	45.7	31.0	40	5.0	4.0	M6	22	160	150

Designation	J	K	L	M	N
LSWL20-80-2Z	71	5.5	60	-	9
LSWL30-88-2Z	80	5.0	70	15	5
LSWL45-150-2Z	135	7.5	120	23	8.5
LXWL20-80-2RS	71	5.5	60	-	9
LXWL30-88-2RS	80	5.0	70	15	5
LXWL45-150-2RS	135	7.5	120	23	8.5