

Lube Unit with Sealing Function

Lube units with sealing function are used in applications with higher mileage or in dirty environments. Located inside the blocks and impregnated with oil ISO VG100, they ensure a continuous lubrication and simultaneously act as front seals. Due to this a service life of 12500 km is possible, without further lubrication. After it is possible to lubricate via the lubrication oil connections or the enclosed grease nipple. Optimally is when you replace the whole unit. The lube units are simply pushed over the rail and mounted by the attached bayonet fittings at the front side of the runner block, when the existing seal unit is removed.

Dimensions in mm.



General Data

Designation	Remark	Lubrication
dsF15	Supplied grease nipple nSN-00M3	Oil 0.65 cm3
dsF25	Supplied grease nipple nGN-00M6	Oil 1.7 cm3

Dimensions

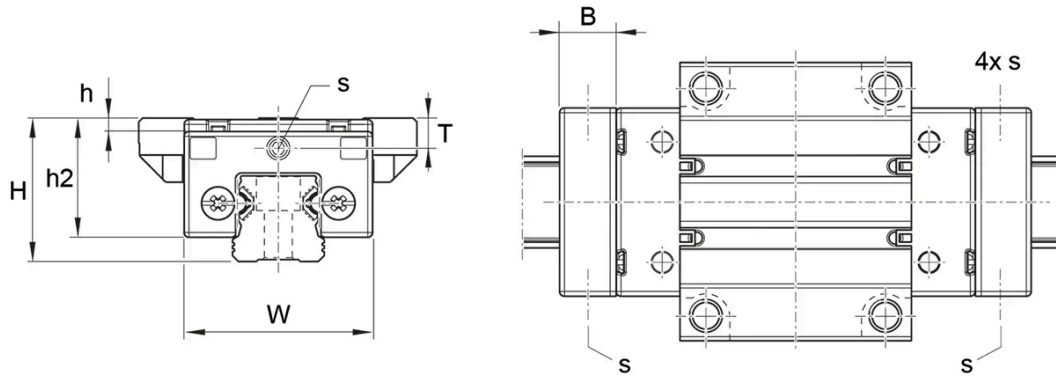

Designation	H	W	h	h2	B	S	T
dsF15	24	31.7	0.4	19.4	11.5	M3	4.5
dsF25	36	47.2	3.4	30	17.2	M6	7.6