

NBR Seal / Metal Scraper

External seal with metal scraper, available for applications under harsh environments. Dustproof solution for milling machining, machinery processing, wood-working or other outdoor applications. It demonstrates high dust-proof ability to prevent contamination from fine dust, iron scrap or dirt.

Installation

1. Set block on the rail before installing external NBR seal.
2. Make sure rubber part is fitted in the sleeve. If rubber parts fall off, please set the sleeve to the correspondent bore.
3. Overlap rubber part and metal scraper with the corresponding salient point and the bore. cpc logo must be facing outward.
4. Slide the external NBR seal into rail from two sides and closely connect with the block.
5. Fasten screw into the correspondence bore. Make sure the seal is centre aligned with the rail while fastening. Do not make metal scraper contact with guide rail.

Dimensions in mm.

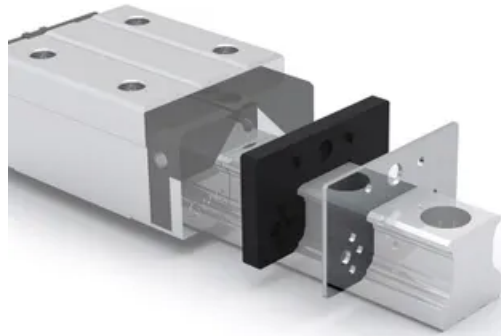

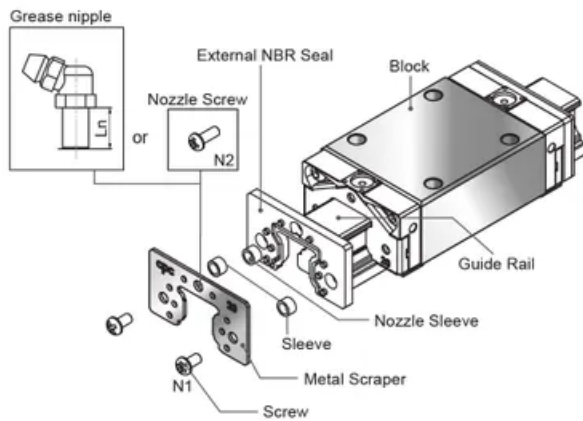

Dimensions

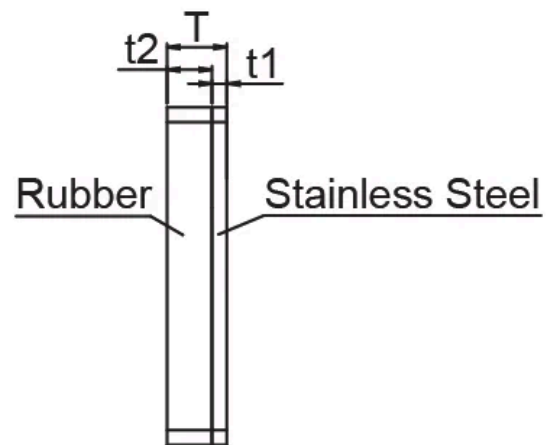
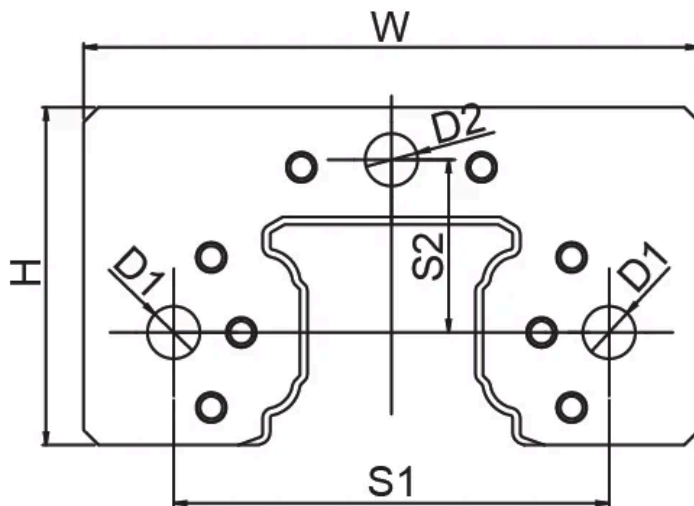

Designation	W	H	T	D1	D2	N1	S1	S2	N2
SN15	33	20.3	4	3.5	3.5	M3x0.35	25	10.2	M3x0.5
SN20	41	22.5	4	3.5	3.5	M3x0.35	29	11.5	M3x0.5
SN25	47	26.5	5.2	4.5	6.5	M4x0.5	36.5	13.5	M6x0.75
SN30	58	34.2	6	4.5	6.5	M4x0.5	42.5	17.5	M6x0.75
SN35	68	39.3	6	4.5	6.5	M4x0.5	50	20.5	M6x0.75
SN45	84	49.6	6	4.5	10	M4x0.5	65	24.9	PT1/8
SN55	98	57	6	5.5	6.5	M5x0.5	73	28	M6x0.75

Designation	Ln	t1	t2
SN15	9	1	3
SN20	9	1	3
SN25	12	1.2	4
SN30	12	1.5	4.5
SN35	12	1.5	4.5
SN45	15	1.5	4.5

Designation	Ln	t1	t2
SN55	16	1.5	4.5