

SBI HLL / SBI CLL

Slim, long, low height block without flange. Side nipple, dustproof end seal and self-lubricant container end seal as option.

* S: Bolt size for bottom mounting type of block

All blocks and rails are also available in Raydent treated material:

- Corrosion resistant
 - Patented black surface
 - Delivered with steel balls of standard bearing steel.
- Stainless steel balls are available on special request and for a few sizes only. Contact Rollco for more information.

Dimensions in mm.

Lead times in the table below are only indications. Choice of preload and other options will affect lead time. Please contact us for exact delivery time for your request.

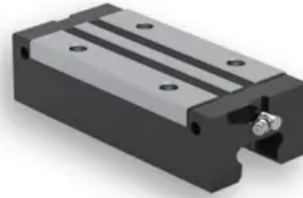

General Data

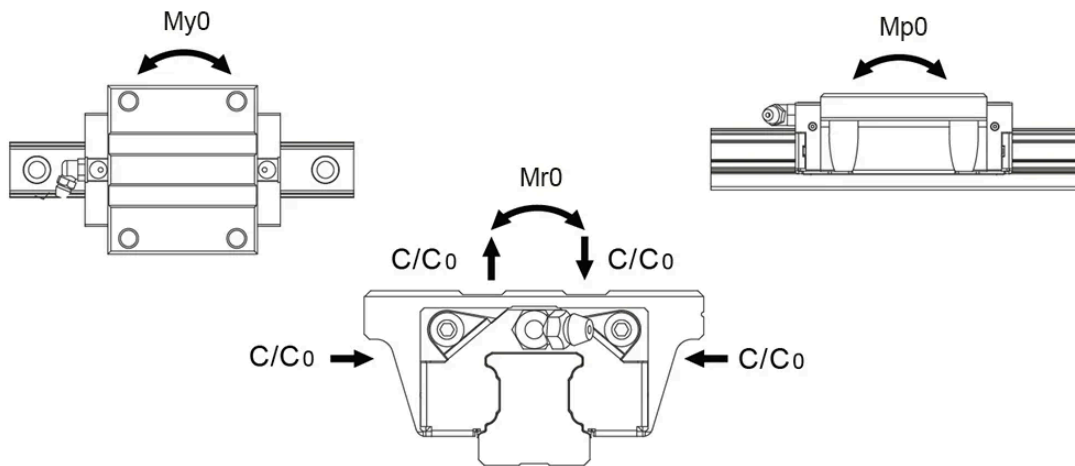

Designation	Dynamic Load Capacity C (N)	Static Load Capacity C0 (N)	Static Moment Mr0 (Nm)	Static Moment Mp0 (Nm)	Static Moment My0 (Nm)
SBI15HLL	17100	31700	210	290	290
SBI20CLL	27900	50000	470	560	560
SBI25CLL	36700	64400	690	840	840
SBI25HLL	36700	64400	690	840	840
SBI30HLL	51300	84700	1100	1300	1300
SBI35HLL	71300	115300	1830	2120	2120
SBI45HLL	94800	150500	3210	3140	3140
SBI55HLL	147900	224500	5950	4780	4780

Designation	Dynamic Moment Mr (Nm)	Dynamic Moment Mp (Nm)	Dynamic Moment My (Nm)	Weight Block (g)	Weight Rail (g/m)
SBI15HLL	113	156	156	260	1300
SBI20CLL	262	312	312	520	2200
SBI25CLL	393	479	479	820	3000
SBI25HLL	393	479	479	850	3000
SBI30HLL	666	787	787	1370	4250
SBI35HLL	1132	1311	1311	2040	6020
SBI45HLL	2022	1978	1978	3690	9770
SBI55HLL	3920	3149	3149	5820	13720

Dimensions

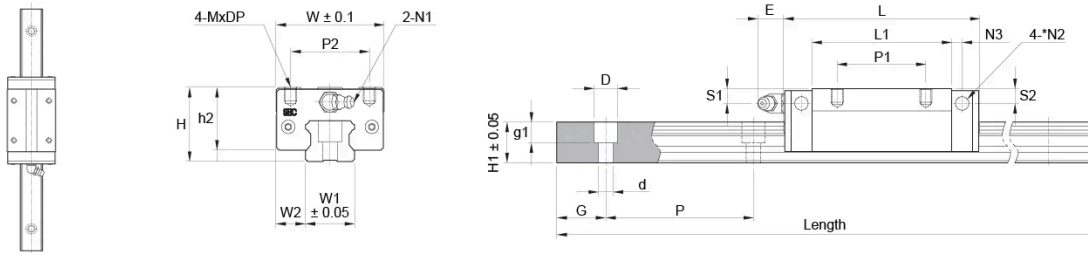

Designation	L	H	W	W1	W2	L1	H1	h2	S1
SBI15HLL	79.4	24	34	15	9.5	60.8	13	21	4.5
SBI20CLL	96.4	28	44	20	12	74.4	16.5	23.4	4.8
SBI25CLL	108	33	48	23	12.5	86	20	27.5	5.4
SBI25HLL	108	36	48	23	12.5	86	20	30.5	6
SBI30HLL	131.6	42	60	28	16	103.6	23	35	8.5
SBI35HLL	152.6	48	70	34	18	122.6	26	40.5	8
SBI45HLL	174	60	86	45	20.5	140	32	51	10.5
SBI55HLL	211.8	70	100	53	23.5	170.4	38	58	12

Designation	S2	D x d x g1	Hole Pitch (P)	MxDP	N1	N2	N3	P1	P2	E
SBI15HLL	3.8	7.5 x 4.5 x 5.5	60	M4x4	M4x0.7	Ø 3.5	3.8	34	26	5.5
SBI20CLL	4	9.5 x 6 x 8.5	60	M5x5	M6x0.75	Ø 3.5	5	50	32	12
SBI25CLL	5.4	11 x 7 x 9	60	M6x6	M6x0.75	Ø 3.5	5	50	35	12
SBI25HLL	5	11 x 7 x 9	60	M6x6	M6x0.75	Ø 3.5	5.5	50	35	12
SBI30HLL	7.8	14 x 9 x 12	80	M8x8	M6x0.75	Ø 5.7	5	60	40	12
SBI35HLL	8	14 x 9 x 12	80	M8x8	M6x0.75	Ø 5.7	6	72	50	12
SBI45HLL	9.3	20 x 14 x 17	105	M10x10	PT1/8	Ø 5.7	6.5	80	60	13.5
SBI55HLL	12	23 x 16 x 20	120	M12x12	PT1/8	Ø 8.7	8	95	75	13

Designation	G	P	Length
SBI15HLL	20	60	3000
SBI20CLL	20	60	4000
SBI25CLL	20	60	4000
SBI25HLL	20	60	4000
SBI30HLL	20	80	4000
SBI35HLL	20	80	4000
SBI45HLL	22.5	105	4000

Dimensions

Designation	G	P	Length
SBI55HLL	30	120	4000