

## MR-W ZUE Series

Wide rail type

End seal, bottom seal, reinforcement plate, lubrication storage.

This product is available in different preload and accuracy classes (see more in Technical Information). Please note that we do not have versions with all preload or accuracy classes on stock.

Dimensions in mm.

See MR-W SS for sizes 3 and 5.

Please note that blocks and rails are not sold separately for sizes 2,3 and 5. Due to the small dimensions, blocks and sliders must be assembled and matched carefully to ensure correct quality and tolerances.

Lead times in the table below are only indications. Choice of preload, accuracy class and other options will affect lead time. Please contact us for exact delivery time for your request.

**Material:** Stainless steel



## General Data

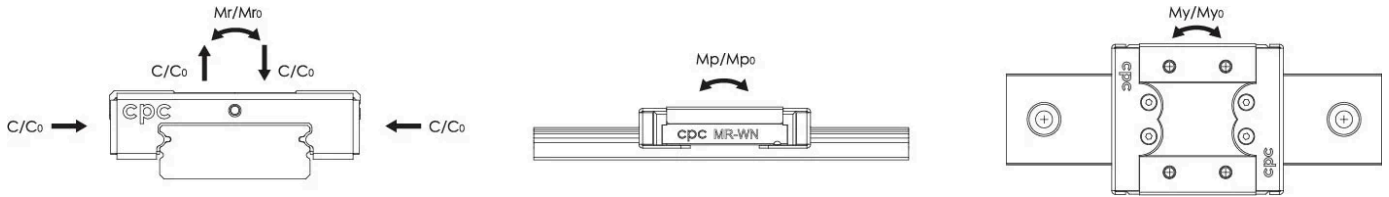

Designation	Dynamic Load Capacity C (N)	Static Load Capacity C0 (N)	Static Moment Mr0 (Nm)	Static Moment Mp0 (Nm)	Static Moment My0 (Nm)
MR2WL-ZUE	310	625	1.6	1.2	1.2
MR7WN-ZUE	1180	2095	15	7.3	7.3
MR7WL-ZUE	1570	3140	22.65	14.9	14.9
MR9WN-ZUE	2030	3605	33.2	13.7	13.7
MR9WL-ZUE	2550	4990	45.9	26.7	26.7
MR12WN-ZUE	3065	5200	63.7	26.3	26.3
MR12WL-ZUE	4070	7800	95.6	56.4	56.4
MR15WN-ZUE	5065	8385	171.1	45.7	45.7
MR15WL-ZUE	6725	12580	257.6	93.1	93.1

Designation	Dynamic Moment Mr (Nm)	Dynamic Moment Mp (Nm)	Dynamic Moment My (Nm)	Weight Block (g)
MR2WL-ZUE	0.79	0.6	0.6	3
MR7WN-ZUE	8.4	4.1	4.1	19
MR7WL-ZUE	11.3	7.5	7.5	27
MR9WN-ZUE	18.7	7.7	7.7	37
MR9WL-ZUE	23.5	13.6	13.6	51
MR12WN-ZUE	37.5	15.5	15.5	68
MR12WL-ZUE	49.9	29.4	29.4	96
MR15WN-ZUE	103.4	27.6	27.6	140
MR15WL-ZUE	137.7	49.8	49.8	203

## Dimensions

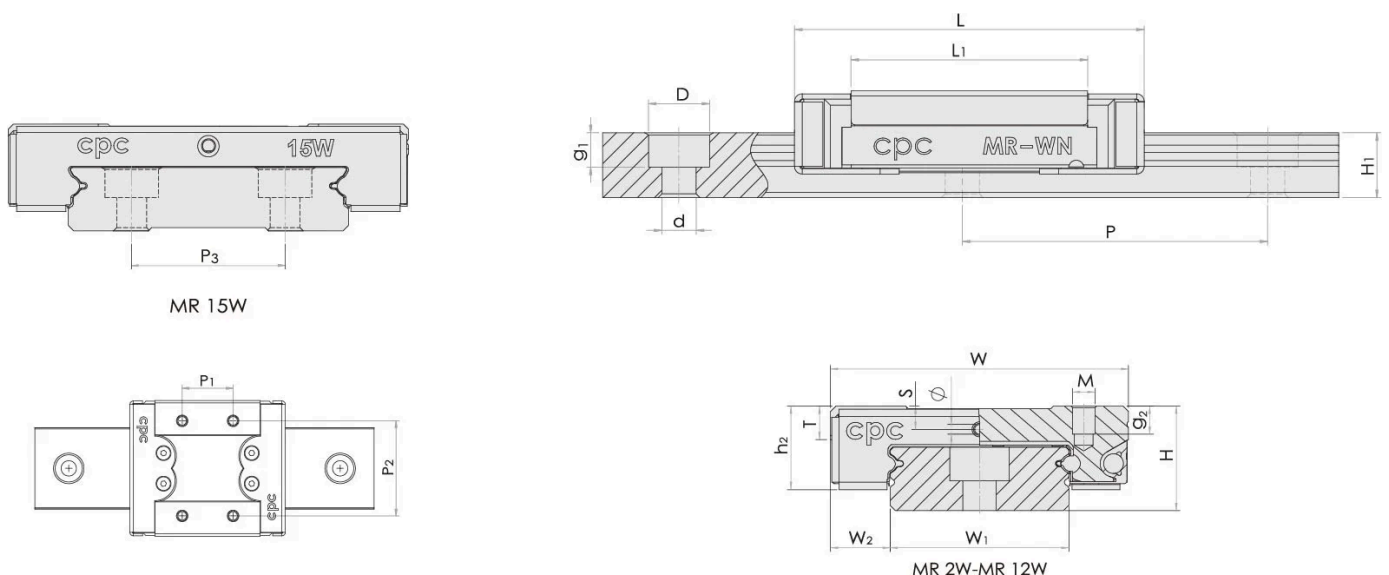

Designation	L	H	W	L1	H1	h2	W1	W2	S
MR2WL-ZUE	17.5	4	10	11.9	3	3.4	4	3	-
MR7WN-ZUE	32.8	9	25	21.2	5.2	7.9	14	5.5	1.9
MR7WL-ZUE	41.6	9	25	30.1	5.2	7.9	14	5.5	1.9
MR9WN-ZUE	40.4	12	30	27.9	7.3	9.5	18	6	2.6
MR9WL-ZUE	51.9	12	30	39.5	7.3	9.6	18	6	2.6
MR12WN-ZUE	46.1	14	40	31	8.5	11.5	24	8	3.1
MR12WL-ZUE	61.1	14	40	46	8.5	11.4	24	8	3.1
MR15WN-ZUE	57.5	16	60	38.5	9.5	13.2	42	9	3.3
MR15WL-ZUE	76.5	16	60	57.6	9.5	13.2	42	9	3.3

Designation	T	D x d x g1	Hole Pitch (P)	M x g2	P1	P2	P3	∅
MR2WL-ZUE	1.3	2.8 x 1.8 x 1.0	10	M2x1.3	6.5	-	-	-
MR7WN-ZUE	3.2	6 x 3.5 x 3.5	30	M3x3	10	19	-	1.1
MR7WL-ZUE	3.2	6 x 3.5 x 3.5	30	M3x3	19	19	-	1.1
MR9WN-ZUE	4	6 x 3.5 x 4.5	30	M3x3	12	21	-	1.3
MR9WL-ZUE	4	6 x 3.5 x 4.5	30	M3x3	24	23	-	1.3
MR12WN-ZUE	4.5	8 x 4.5 x 4.5	40	M3x3.5	15	28	-	1.3
MR12WL-ZUE	4.5	8 x 4.5 x 4.5	40	M3x3.5	28	28	-	1.3
MR15WN-ZUE	4.5	8 x 4.5 x 4.5	40	M4x4.5	20	45	23	1.8
MR15WL-ZUE	4.5	8 x 4.5 x 4.5	40	M4x4.5	35	45	23	1.8